

**parla\***



**Collection 2025**

# Index

Our Message	3
The History of Parla	5
A Sustainable Future	11
Parla Bespoke	15
Our Design Ethos	19
The Design Team	21
Parla Collection	25
Details	105
Materials & Colours	163



# parla\*

CELEBRATING  
115 YEARS  
OF CRAFTS  
HERITAGE

OUR MESSAGE

Parla is an Istanbul based family business, with crafts heritage spanning four generations.

We know why we shine bright;

We are talented.  
We love craft.  
We are tech oriented.  
We work hard.  
We move fast.  
We are agile.  
We are fully collaborative.  
We thrive on problem solving.  
We are a dedicated project partner.

We achieve the dreams of our project partners and we shine brighter together!

# A message from the Light Bearers of Parla



←  
Hakan Oztuncman  
Owner Director

→  
Burak Oztuncman  
Owner Director



At Parla we are dedicated to chasing the light.

The blessed light of our great grandfather who started this business as a loyal and respected furniture maker of The Ottoman Imperial Family.

The guiding light of our father, who taught us that we must take care of our customers and employees equally.

The sparkling light of our talented designers and hard-working factory workers.  
And the light we see in the faces of our delighted customers.

At Parla what uplifts our day is not just creating beautiful pieces of furniture but creating exceptional, outstanding outcomes and constantly raising the bar when it comes to quality and care.

This vision has built Parla into a reliable, resilient, and globally respected company that designs, crafts and manufactures pieces that stand the test of time.

Every day, we are ready than ever, we are here to add light into your projects, and shine brighter together with you.

# Fusing Crafts & Design



The story of Parla began with the first generation crafting furniture for the Ottoman Empire and over time we have evolved into a modern operation with a showroom and 15,000sqm factory in Istanbul plus presence in London, New York, Miami, and Dubai.

With an in house team of 15 young and dynamic designers, a factory of highly skilled craftsmen in areas such as wood, metal, glass and upholstery, over 300 employees are working tirelessly to continue the legacy.

We also welcome well known architects and designers to join us in creating new pieces, and run 'Product Creation Workshops'. In these workshops we marry the designer's expertise & innate talent with Parla's traditional & modern craft techniques along with a strong culture of pushing boundaries.

We operate globally, but our approach is to become local to each region; this enables us to provide logistical support to our clients across various time zones and assures them a continuity of service from design, to delivery, to manufacturing and to aftersales. Our "can do" approach, teamed with superior customer service makes us stand out from the crowd, and win consistent repeat business with our clients.

# Heritage of Parla

**1910**  
GREAT GRANDFATHER  
YAKUP ÖZTUNÇMAN  
Parla Design dates back three generations.  
The great grandfather Yakup Öztunçman was employed as a furniture maker in the Dolmabahçe Palace in Istanbul.

**1929**  
First atelier was in Akareler, Istanbul.

**1963**  
FATHER  
ERDOĞAN ÖZTUNÇMAN  
Güven Ticaret was established in Oto Sanayi as an outdoor furniture production facilities by Telat Öztunçman and his son Erdoğan Öztunçman.

**1989**  
Ergah Madeni Eşya San. Tic. LTD.ŞTİ. was established by Father Erdoğan Öztunçman and Şahin Yılmaz. Ergah brand was created from the first letters of two partners which lay the foundations of Parla Design.  
**ERŞAH**  
Few samples of antique wrought iron chairs, tables, planters, swings.

**1991**  
6000 sqm factory was built in Arnavutköy-Istanbul.

**1996**  
First aluminium chair produced in Turkey.

**2002**  
Beginning of cooperation with designers. Rodeo Sunbed designed by Alper Böler and Ömer Ünal.

**2006**  
Retail store opened at Bucharest - Romania and Moscow - Russia.  
MOSCOW SHOWROOM  
BUCHAREST SHOWROOM

**2007**  
PARLA®  
Trademark has been registered as PARLA.

**2010**  
In-house design team build.

**2011**  
Parla's corporate identity has been redesigned according to an expression and reflection of an company's culture.  
PARLA®

**2013**  
Give a better service to our customers, retail store opened at Fulya, Istanbul.  
ISTANBUL SHOWROOM

**2014**  
Retail store opened at Hub of Middle East, Dubai - UAE.  
DUBAI SHOWROOM

**2015**  
UK - representatives and office based in London, UK.  
LONDON OFFICE

**2018**  
Parla continue their journey working with renowned designers such as Arketipo, LaGranja & David Fox to launch new products.

**2019**  
A new production site was added to the main factory, making the total production area 15000 sqm.

**2020**  
Collection Business Division was established.  
US Office

**2021**  
US Office is opened.  
Parla launched its new corporate identity.

**2022**  
Sustainability goals have been established and an in-house sustainable manager has started.  
parla\*



# A Sustainable Future

We really do care...

About society, about the environment, about the economy. We care about how we impact the environment. Nature is our mother! We care about looking after her, and leaving the right kind of legacy for future generations.

We manufacture with sustainability in mind, constantly developing ways to be more in harmony with nature when using resources such as wood, steel, aluminium, textiles and plastics.

We care about people; we care about women, we care about young people. And, like many companies in this sector it is 'work in progress'; everyday we are realising more about what we can do and how we can implement changes.

Using the UN Sustainable Development Goals list as a yardstick, we have set up an internal team that prods, probes and pushes the whole company to do better. Of course not all 17 of the goals are related to our business, but the Goals that we feel we are really working on are:

- #3 Good Health and Well-Being**
- #4 Quality Education**
- #5 Gender Equality**
- #6 Clean Water and Sanitation**
- #7 Affordable and Clean Energy**
- #8 Decent Work & Economic Growth**
- #9 Industry, Innovation & Infrastructure**
- #10 Reduced Inequalities**
- #12 Responsible Consumption and Production**
- #13 Climate Action**
- #15 Life on Land**
- #17 Partnership for the Goals**

Embedding these bigger picture Goals into our company culture is a journey in which we find ourselves inspired to then tackle specific areas on a micro level.

2024

# Corporate Sustainability Report

## SUSTAINABLE DEVELOPMENT GOALS

17

Using the UN Sustainable Development Goals list of 17 main subjects as a yardstick, we have set up an internal team that prods, probes and pushes the whole company to do better. We've based our studies on GRI Standards, and our internal sustainability team is working on developing all environmental, social and economic aspects of our company in accordance with these standards.

90%

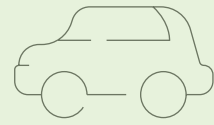

Carbon Emissions Of Staff Transportation



# Our Practical Development Goals

150 hours face to face

The Number of Online Training Hours for Staff

15 Tons of Plastic & Paper

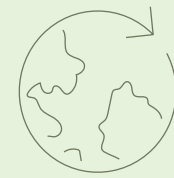

2022-2023

47% of our white collar labour force is female

Social Compliance

2022-41%

60%

Recyclable Packaging

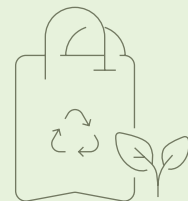

50.000 kg CO2 offsetting

Carbon Neutral Shipping

2022 11.600 kg CO2



90%

Wood used is FSC



35 m3 of sea ice melting

Production improvements is equivalent to lessening in carbon emission



1.338 MWH

Renewable Electricity Consumption

2022 1.233 MWH



2025

- All adhesives and varnishes used will be water based.
- All our plastic packaging will be bio-degradable.
- 70% of our standard fabric options are manufactured in an environmentally conscious manner with Oeko-Tex, Greenguard and/or EU Eco Label certificates.
- 50% of our standard outdoor fabrics are recycled.

2026

- 80% of the products in our collection will use recycled fabrics.
- At least 20% of our Collection's product families will be crafted from sustainable, recycled and/or bio compostible materials.

2027

- We will have put a water recycling system in place for the whole factory and all drinking water will be supplied from these units.
- Our factory will reduce its water consumption by 80%.

2030

- 50% of our Collection's product families will be crafted from sustainable, recycled and/or bio compostible materials.
- Our production facilities will be using a renewable energy source.
- Find out more about our sustainability goals at [parladesign.com/sustainability](http://parladesign.com/sustainability)



# Parla Bespoke

Parla Bespoke offers a service that is customer centric, handcrafts oriented and value engineered. Projects delivered to luxury restaurant, hotel and cruise ship interiors span worldwide, and brands such as Mandarin Oriental, The Peninsula, Four Seasons & Six Senses are a selection of the many esteemed hospitality venues we supply FF&E and in some cases also fitted furniture.

We are proud to say that, over the years, we have delivered case goods, fixed furniture and upholstered items to projects in collaboration with more than 300 restaurants & hotels in over 50 countries. We are now excited to be starting to supply products to cruise ships, offices and large residential projects as well.

Four Seasons Hotel  
Istanbul at Sultanahmet  
Türkiye \* 2022



Hotel Amano Covent Garden  
London \* 2022



Locke am Platz  
Zurich \* 2023



One & Only One Za'abeel — StreetXO  
Dubai \* 2024

# The Process

1



## Discovery

Wherever you are, our teams are ready to invite you to our factory in Istanbul to experience Parla's excellent customer service.

2

## Briefing and Detailed Specification

Briefly explain your design request to our design representatives. Our teams will then prepare precise shop drawings and material samples for your approval.



3

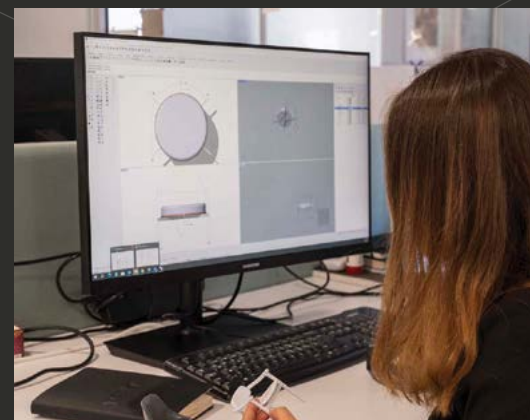

## 3D Design and Approval

Our shopdrawings are prepared in 3D for a better understanding. Approve your orders via e-mail, by accepting Parla's shopdrawings and order confirmation documents.

4

## Prototyping

A prototype will be created for your review before the flow production, which can be sent to you or viewed at the factory as per your request.



5

## Manufacturing

Production starts at the factory. Manufacturing of items takes 4 to 6 weeks

6

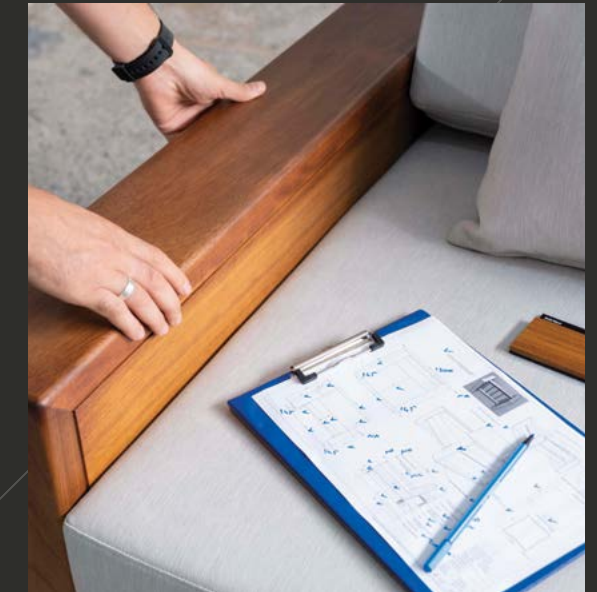

## Quality Control

Quality control tests are carried out in our factory by our teams. You can also inspect the goods or view our reports.

7

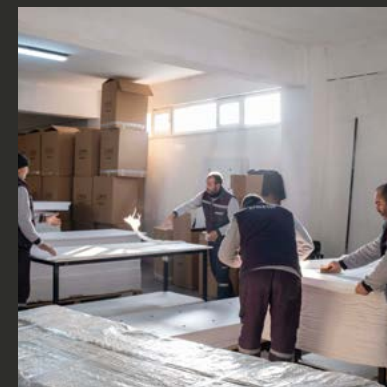

## Delivery and Installation

Items are packed and shipped to you, anywhere in the world. Every month our logistics team dispatch over 30 containers of furniture headed to Hospitality and F&B projects globally.

8

## After Sales

PARLA will continue to be your solution partner, offering you 24 months of warranty and supporting you with any issues or further requests that you may have.



# Our Design Ethos

## FUSION

In each of our designs we fuse influences from our rich cultural heritage and the artisanal. We apply this to design, to form, to technique and to use of materials.

## HARMONY

Every piece of furniture we design, craft and manufacture is a true reflection of our client's vision and sits in harmony with the environment it is being placed in.

## RESPECT TO RESOURCES

In both design and manufacturing we set limits to how we apply our vast pool of resources and knowledge so that we are not exorbitant with the use of time, materials and labour.

# The Design Team



# Designers



**Betül İnci**

Betül who is Head of the Parla Design Team, studied Industrial Product Design at Istanbul Technical University and Linnaeus University in Sweden, then furniture design at The Florence Institute of Design. A multicultural approach influences her minimalist yet bold design style. With 12 years at Parla, she has worked on many projects, she won the Good Design Award with her Nigiri Chair in 2021 as well as many other awards.



**Aysel İlisik Aydinok**

Former Project Manager and Senior Designer at Parla, Aysel studied Industrial Design at Anadolu University and then began her career in Istanbul. With expertise in furniture design and hospitality interiors, she now leads Designer Relations at Parla, focusing on building strong customer relationships in the A&D community.



**Berrak İlkcan Sener**

Born in Fethiye and based in Istanbul, Berrak studied Industrial Design at Anadolu University and participated in a student exchange at HAWK Hochschule in Germany. Awarded by BigSee for her Rimo Armchair in 2022, her designs focus on timeless, functional, and user-friendly products with a clean aesthetic.



**Seda Yetkiner**

Seda studied Industrial Design at Anadolu University and began her career at Yakamoz Glass, where she mastered hot glass production, now her passion. Joining Parla Design Studio in 2019, she expanded her expertise with new materials. Her designs feature bold, functional shapes with elegant details.



**Deniz Albayrak**

Born in Bulgaria, Deniz studied Industrial Design at Anadolu University and moved to Istanbul after graduation. Starting as a product designer at Parla, he then co-founded Parla Studio and is now Head of Technical Sales, leading projects and architects from Parla's London office.



**Erden Dereli**

After graduating from Anadolu University, Erden interned at d'Arc Studio Roma before joining Parla as an Industrial Designer and later as a Production Planning Manager. A co-founder of Parla Studio, he now specializes in production processes, focusing on materials, functionality, manufacturability, and R&D.



**Yasemin Derici Ceri**

Yasemin is a designer with a background in Industrial Design, focusing on various aspects of the field. She has honed her skills in furniture design, set design, prop styling, and creating visual and digital assets for marketing, bringing a multi-faceted perspective to her work. Yasemin continues her career as an Art Director in Lisbon.



**Enis Altinkaynak**

Enis, a graduate of Anadolu University with a Master's Degree from Marmara University, researches the impact of modern technologies on product design while lecturing at Beykent University. He embraces all design ideologies but prefers a totalitarian approach, constantly seeking excellence in materials and production processes.

# Collaborators



**Jean-Michel Willmotte**

Jean-Michel Willmotte, founder of Willmotte & Associés in 1975, is a French architect and urban planner. His firm, operating in 23 countries with 270 employees, specializes in luxury, hospitality, residential, and commercial projects. Willmotte also founded the design studio Willmotte & Industries.



**Kunter Sekercioglu / Kilit Tasi Design Studio**

Kilit Tasi, based in Istanbul, offers industrial design, design management, and strategic consultancy across various sectors. Partner and Design Director Kunter Sekercioglu draws inspiration from culture, craftsmanship, and daily life. He ensures quality by being actively involved in every stage of the design process.



**Klan Studio**

Founded by Esref Akin Oral and Isik Gorgun Oral, Klan Studio specializes in furniture, yacht, and machinery design. They define themselves as modernists, prioritizing efficiency, clever design, and consistency, always delivering the 'right design' for each project brief.



**Matthew Goodrich & Hines Fischer**

Goodrich is a multidisciplinary design practice specializing in hospitality, offering branding, interior design, strategy, and product design. Driven by curiosity and empathy, they create unique, integrated solutions and work with collaborators to design impactful environments for communities.



**Burcu Ozdamar**

After graduating from Middle East Technical University, Burcu joined Parla, where she collaborated with craftsmen to explore materials closely. Her designs blend different textures, geometric forms, and East-West influences. Known for customizable products, Burcu is now a product manager and continues her personal design projects.



**Umut Karginoglu**

Born in Gaziantep, Umut studied Industrial Product Design at Istanbul Technical University and settled in Istanbul. Gaining experience in office, restaurant, and urban furniture design, he specializes in product design, model making, branding, and concept generation, with strong engineering skills. He is currently a Product Design and Development Specialist.



**Esin Sozer Kalender**

Founded in 1994 by Murad Denizalti, Muge Hansoy Kinaci, and Esin Sozer Kalender, Arketipo Design has completed over 180 projects worldwide, including hotels, spas, offices, and residential spaces. Their work spans Turkiye, Dubai, Germany, Russia, Libya, Kazakhstan, and Ukraine.



**David Fox**

David Fox Design is a multi-award-winning industrial and product design studio with accolades including Red Dot and Good Design Award. Their work spans furniture, bathroom basins, faucets, hardware, fabric, and carpet design. They serve clients across Belgium, Turkiye, UK, Italy, and more.



**Buket Hoscan Bazman**

Buket Hoscan Bazman, born in Izmir in 1989, founded 'Marbleous' in 2015, creating marble-detailed furniture and objects. In 2018, she opened her own design studio, focusing on contemporary collectible pieces made using traditional craftsmanship and natural materials by Turkish artisans.

# The Collection

Crafted through the synergy of our 15 in-house designers and international collaborators, the 'Parla Collection' embodies our commitment to design excellence.

Garnering steady expansion over 3 years, we've forged a presence in key markets like the UK, Europe, USA, and GCC, boasting 30+ dealers.

Our global footprint spans New York, London, Dublin, Istanbul, Miami, Dallas, and Dubai, underscoring Parla's evolution into a world-renowned design-focused brand.



# Palm





Designed by  
Jean-Michel Wilmotte

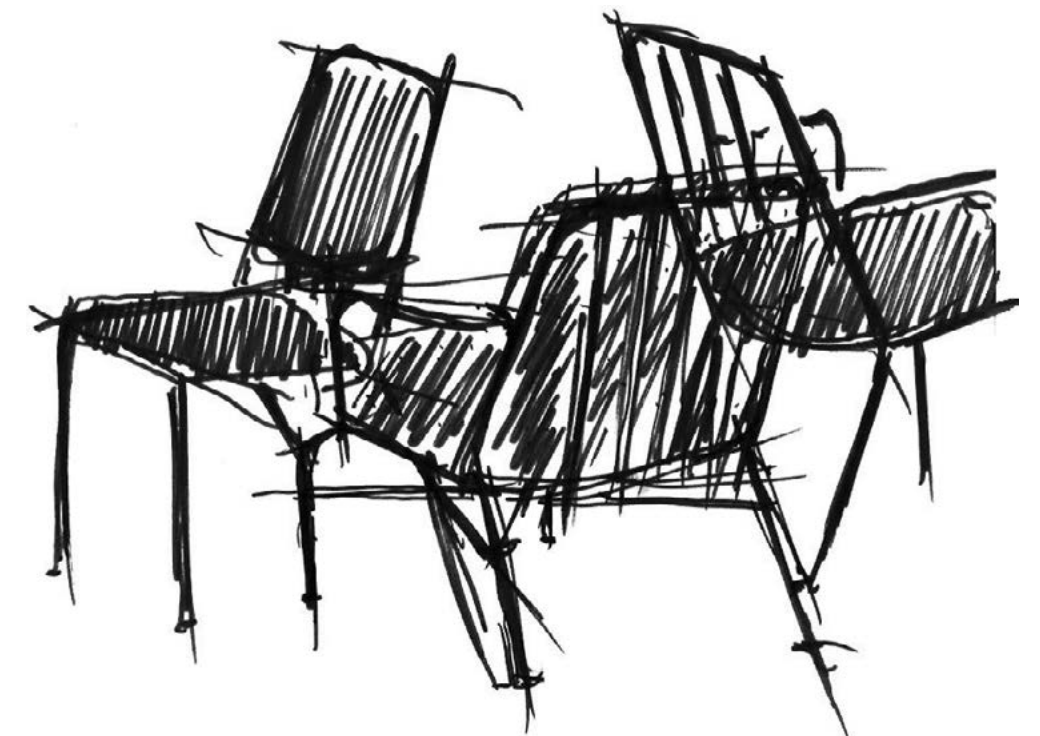





**Frame:** Powder coated metal structure with armrest  
**Seat & Back:** Upholstered seat Armwrap and armrests are optional (additional cost)



Clean lines and subtle elegance are the two distinguishing elements that lead the way in our collaboration with Jean-Michel Wilmotte. “Inside, outside: a new praise of the dark” is how Jean-Michel explains his design ethos for the Palm Collection, using an interplay between light and shadow, sleek lines and block colours, adding rhythm to their surrounding spaces.



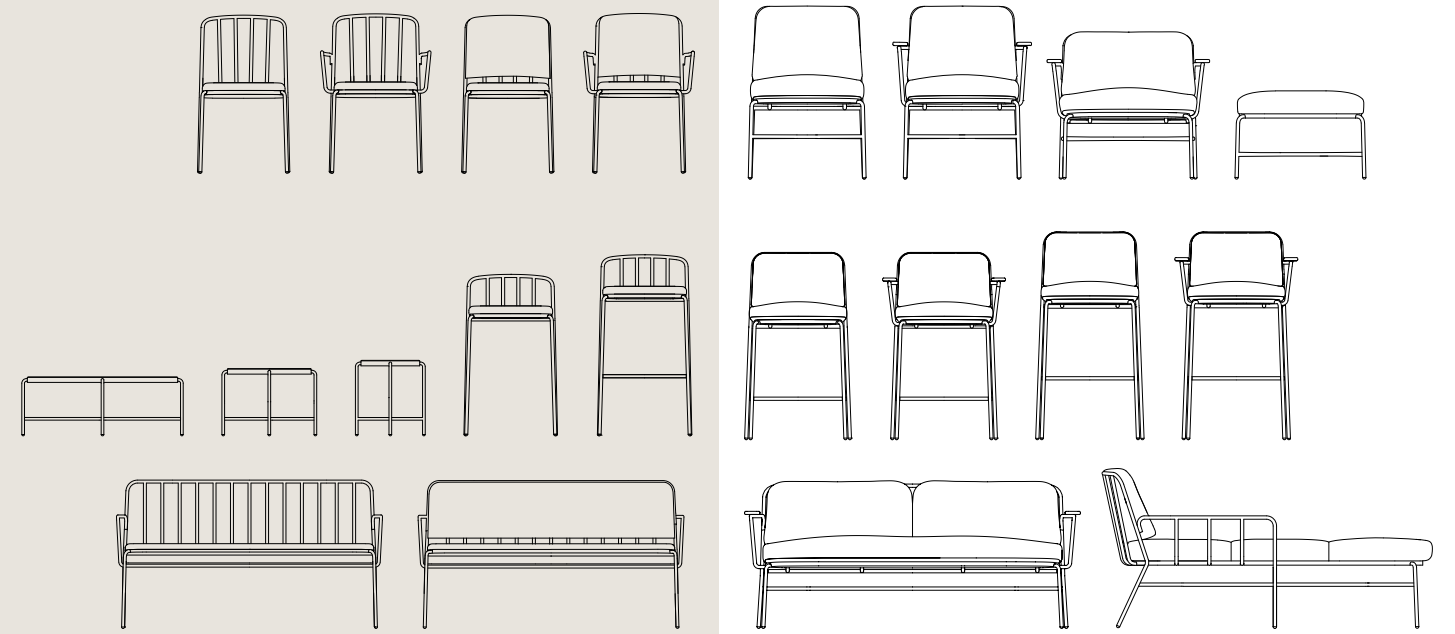

# Hew





Matthew Goodrich &  
Hines Fischer of Goodrich

HEW COLLECTION





Hew marks the first collection designed by Matthew Goodrich and Hines Fischer for Parla.



Instilling a sense of motion in the design, unbroken swaths of fabric give unique opportunities to play with directional and large scale fabric patterns without worrying about seams, and elegantly carved wood pillars separate the sections.

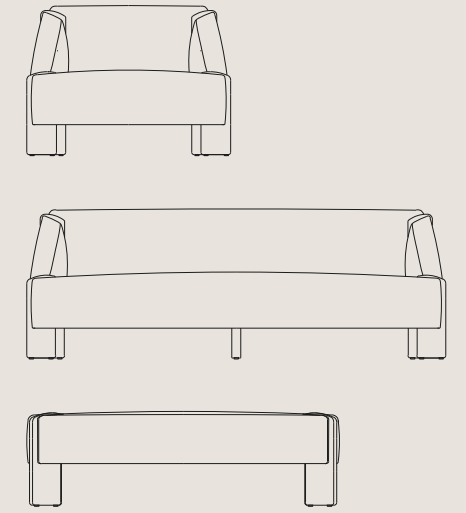

# Hug





Designed by  
Betul Inci

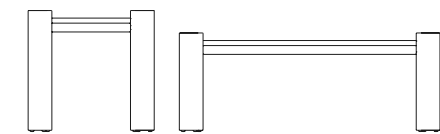
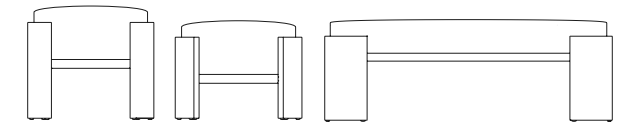
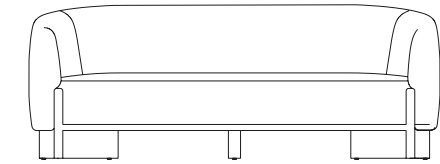
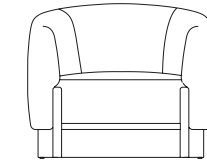

Designer Betul Inci aimed to showcase our exceptional craftsmanship skills in this design, highlighting high-level expertise in both design and woodwork. Offering a contemporary twist on retro furniture, it exudes charm while maintaining the highest quality. Adding warmth and welcome to interiors, Hug is the perfect choice for public spaces in hospitality interiors.



# Loop







## Matthew Goodrich & Hines Fischer of Goodrich

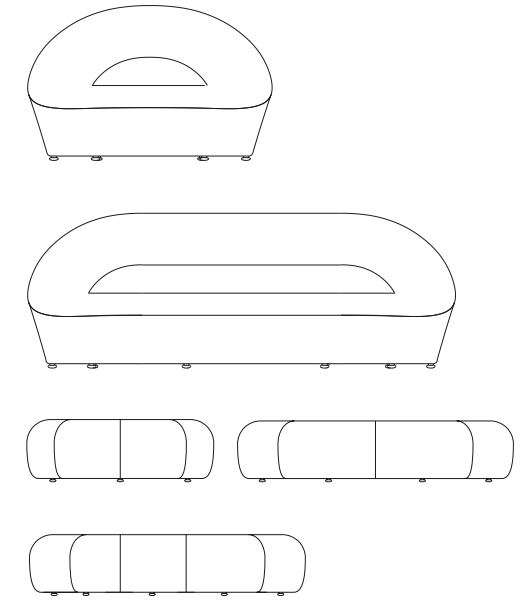

For our second collaboration with Hines Fischer and Matthew Goodrich we developed their design sketch and were able to bring to life a collection of oversized pieces with inviting rounded soft volumes. Making you feel at home, pampered and relaxed, Loop is both aesthetically pleasing and very design conscious.



# Nigiri





Designed by  
Betul Inci

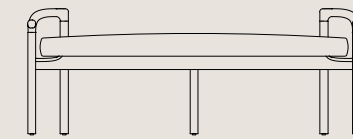
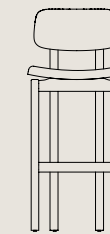
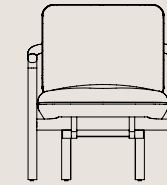
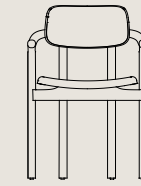

The Nigiri collection blends Far Eastern style with contemporary aesthetics. Distinctive structural lines highlight the artisan craftsmanship of the frame at the same time as giving gentle and supple support for the back. The Nigiri combines traditional and technological methods perfectly in one chair, bringing about contemporary aesthetics.



# Cora





Designed by  
Seda Yetkiner

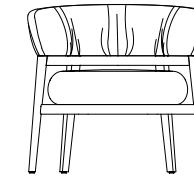
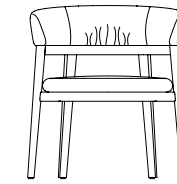

Inviting not only due to the comfort it promises, but also pleasing to the eye, this armchair gives you seating that restores and revitalizes.

Rounded in nature, it creates a sanctuary of a space for the user; and the different sections offer multiple variations in finish, colour and texture. The enticing upholstered sections are supported by an elegant solid wood frame, giving the design a refined look suitable for a variety of hospitality and restaurant interiors.



# Gala





Designed by  
Burcu Ozdamar

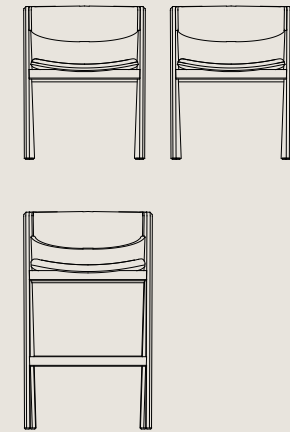

Gala is a nod to the past with excitement for the future. A well balanced design, with comfort and simplicity complimenting a strong frame that is also beautifully crafted.



# Fau

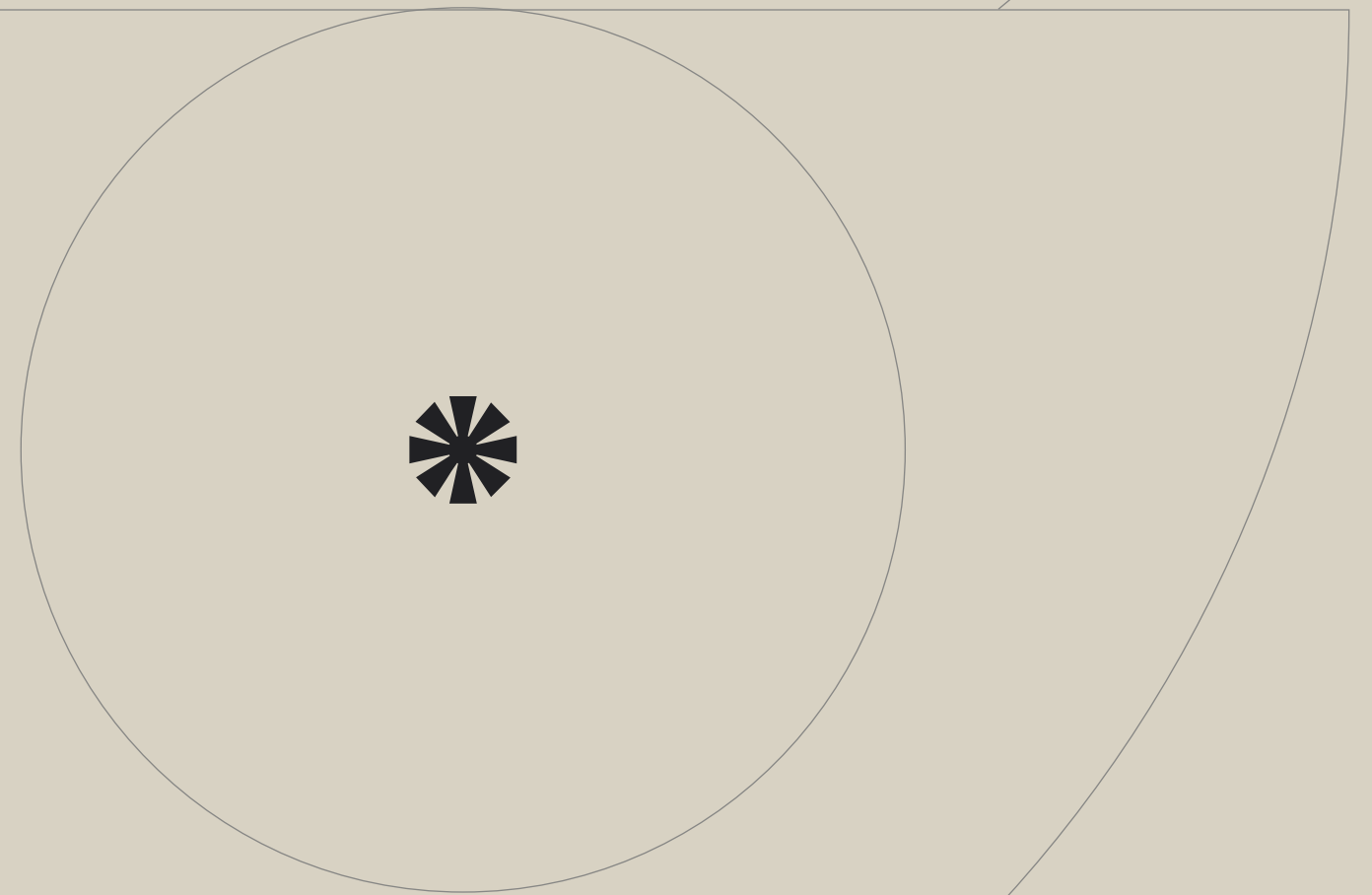





Designed by  
Kilit Tasi Design Studio

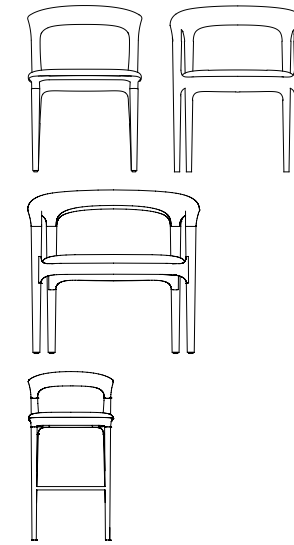

Design, understated glamour and finesse all come together in this chair that has been brought to life through a collaboration with industrial designer Kunter Sekercioglu.

A design wonder of a chair, it stands out of the crowd with its, light but stable structure, comfortable seat, and perfect curves of the wood.



# Oyster

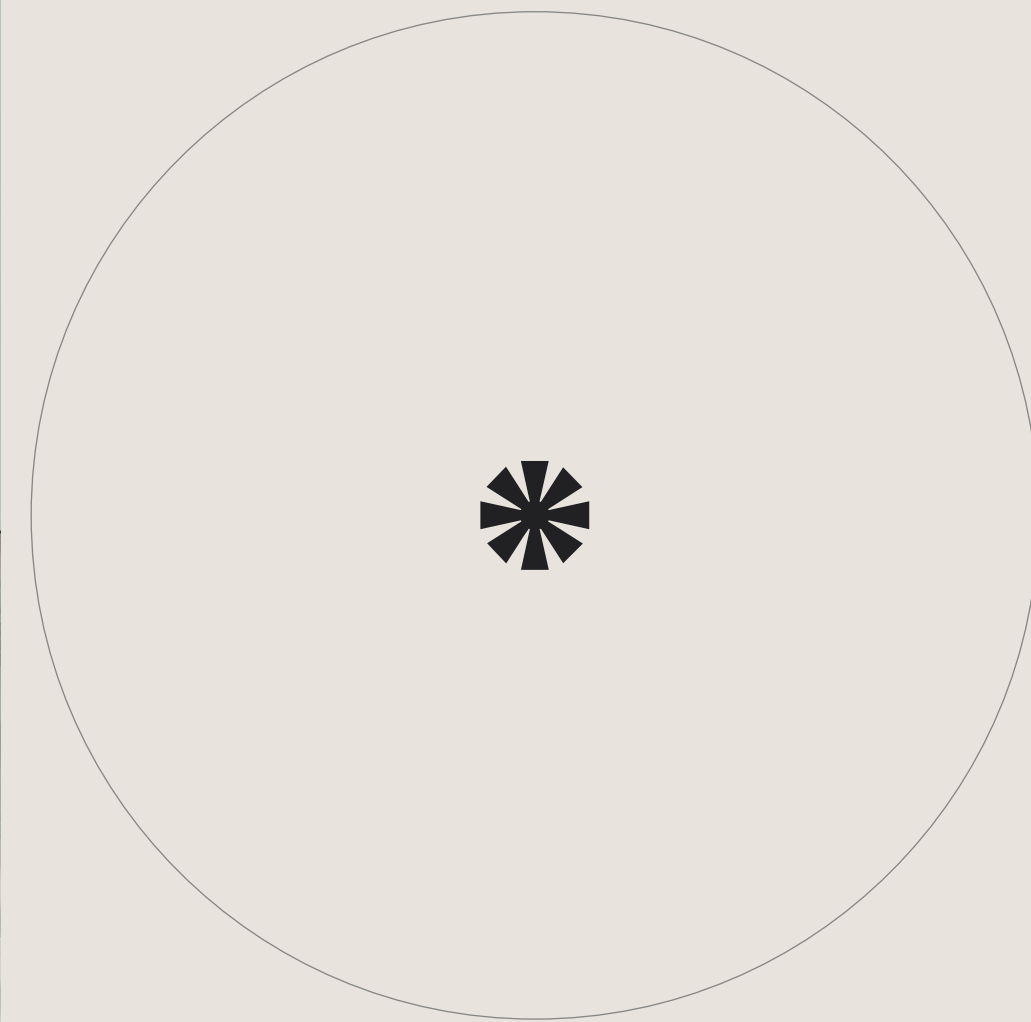



Designed by  
Enis Altinkaynak

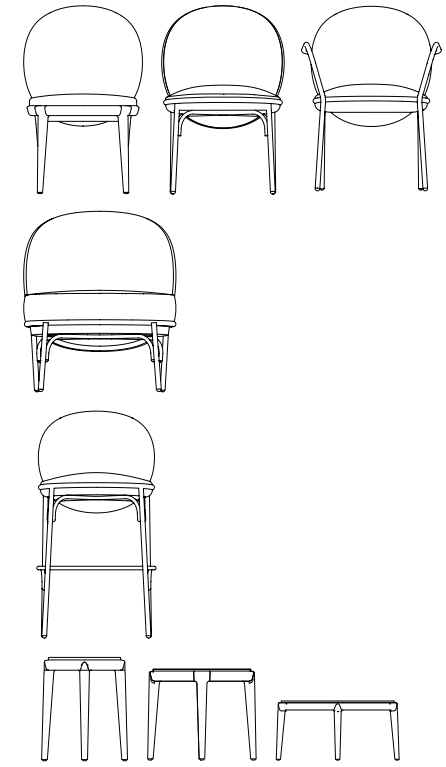

Oyster is a furniture range whose design is inspired by shells and similar natural forms. The characteristic softly rounded silhouette of the upholstery is reminiscent of a seashell. Aimed at both corporate and private environments the Oyster is for indoor use.



# Rimo



 **BIGSEE  
PRODUCT DESIGN  
AWARD 2022  
WINNER**





Designed by  
Berrak Ilkcan Sener

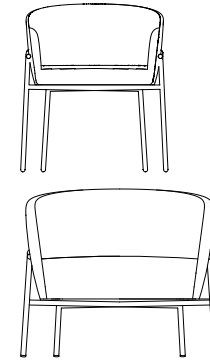

Rimo Armchair combines simplicity and comfort by embracing the user with its soft upholstery. Rimo blends in perfectly with different interiors despite its eye-catching form, comprising of a minimal frame and a generous foam seat.



Cosentino City Istanbul  
Istanbul, Turkiye

# Arven



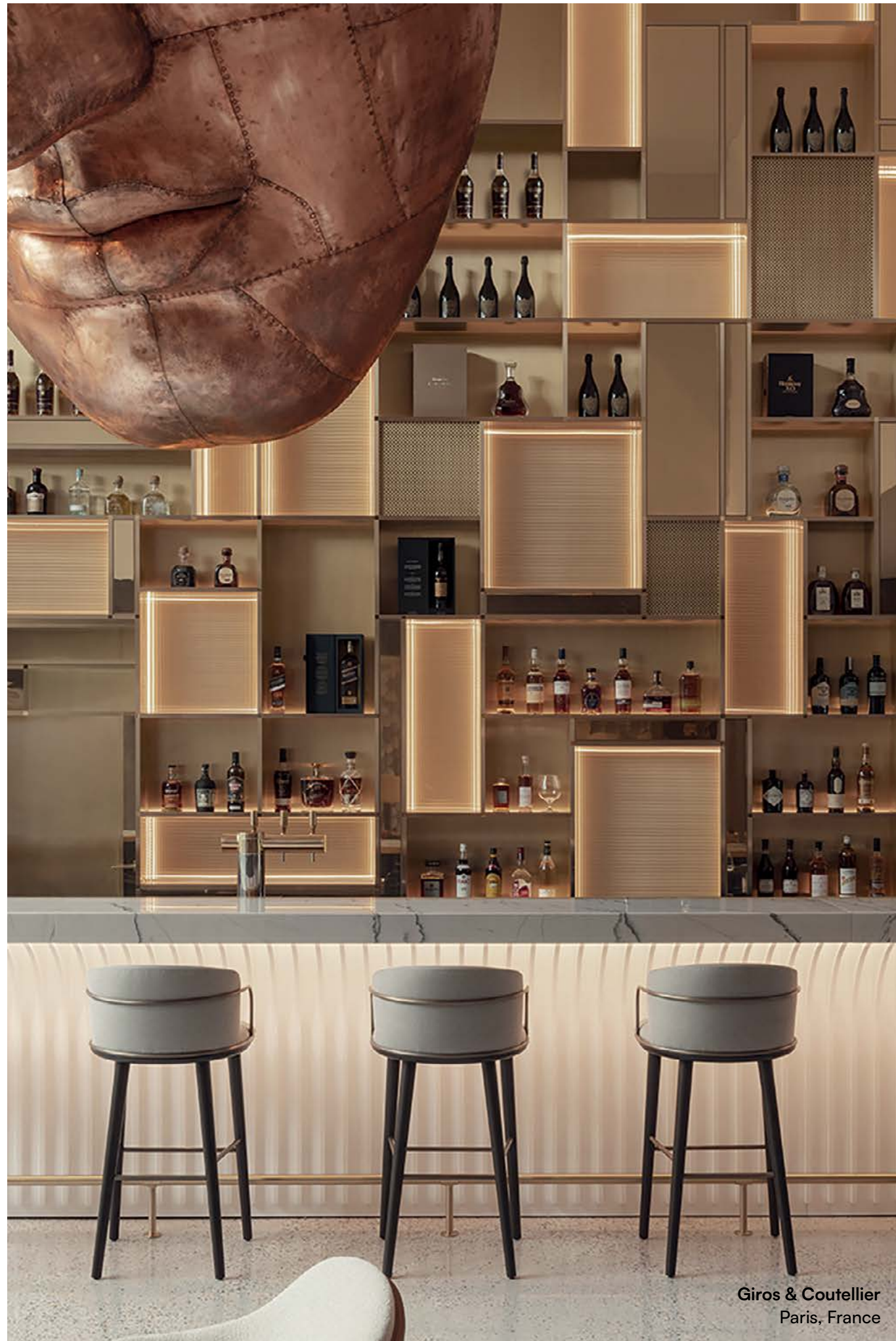

Giros & Coutellier  
Paris, France

Designed by  
Burcu Ozdamar

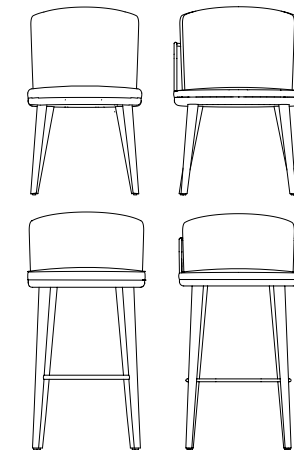

The Arven collection blends contemporary taste with a unique metal frame that highlights the elegant form. The Arven family is a sophisticated collection, which adds a touch of informal elegance to any room in which it is placed.



Pınar Hotel  
Balıkesir, Türkiye

# Xaylon

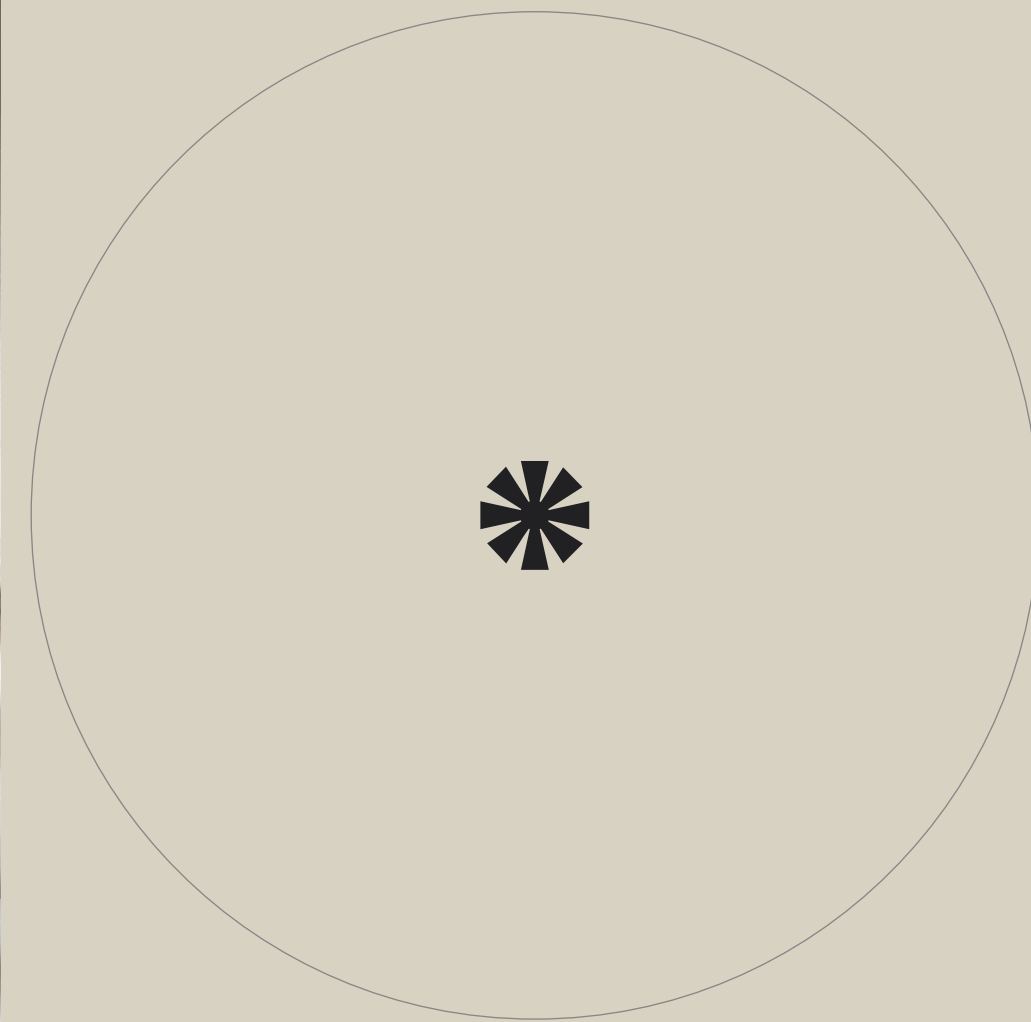



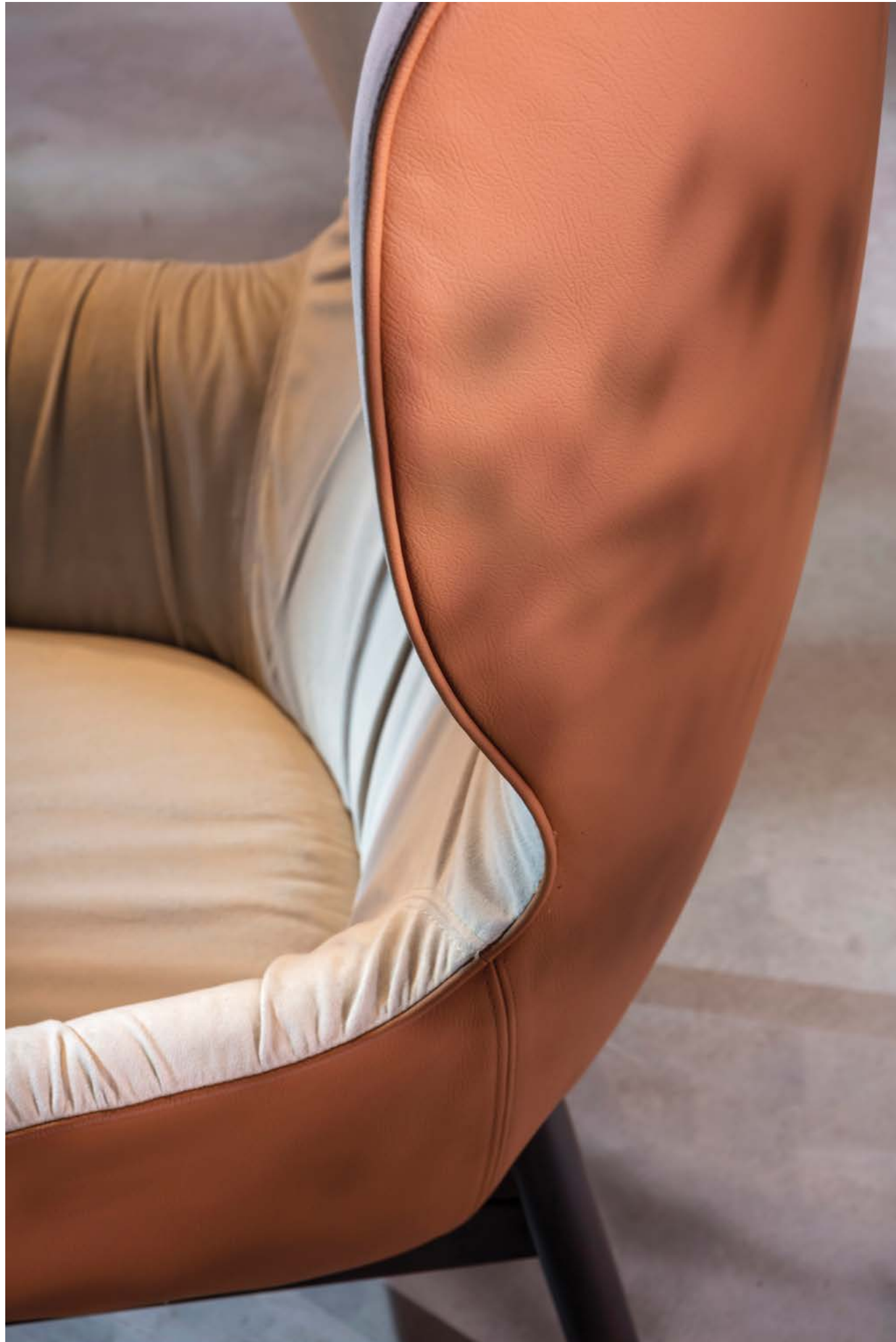

Designed by  
David Fox

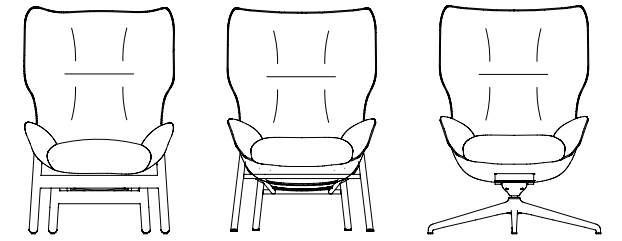

As a statement piece for lounge areas, elegant and luxurious Xaylon Armchair aims to bring a comforting yet refined character to the environment. Xaylon's design contains carefully considered fly, pipe and wrinkle details; reminiscent of the interiors of timeless classic cars. As a statement piece for lounge areas, elegant and luxurious Xaylon Armchair aims to bring a comforting yet refined character to the environment.



# Morwi





Designed by  
Berrak Ilkcan Sener

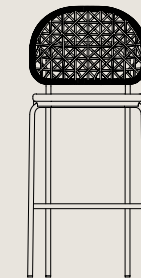
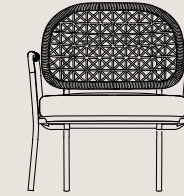
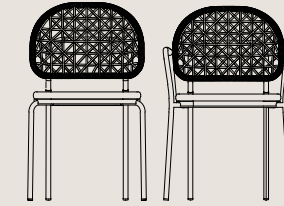

Perfect for summer evenings, our Morwi family of furniture adds joy and dynamism to every scheme; its light frame, and intricate pattern on its back makes this collection the best partner for outdoor wining & dining.

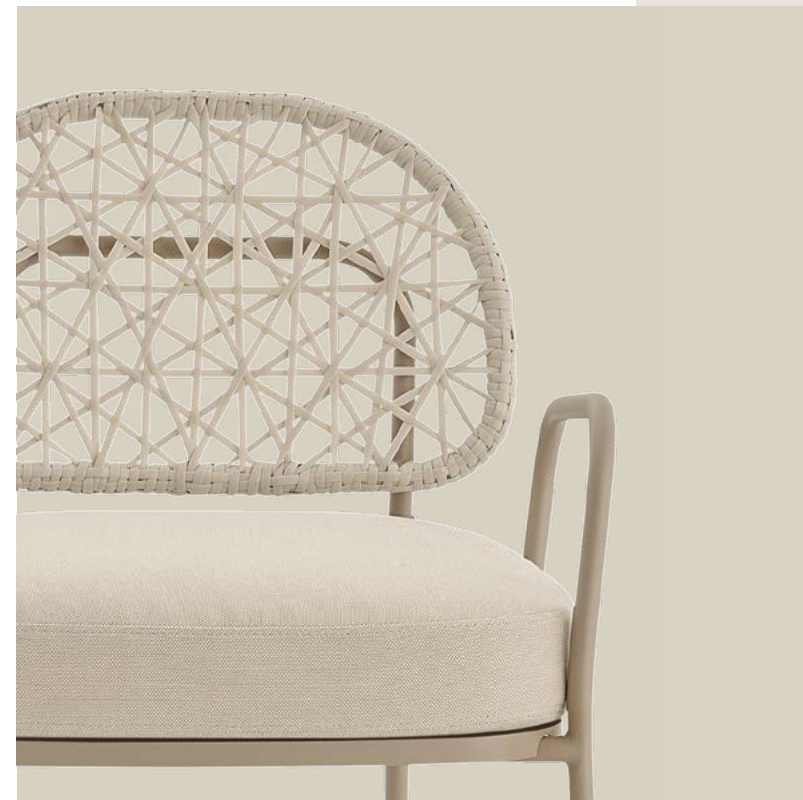

# Atlas

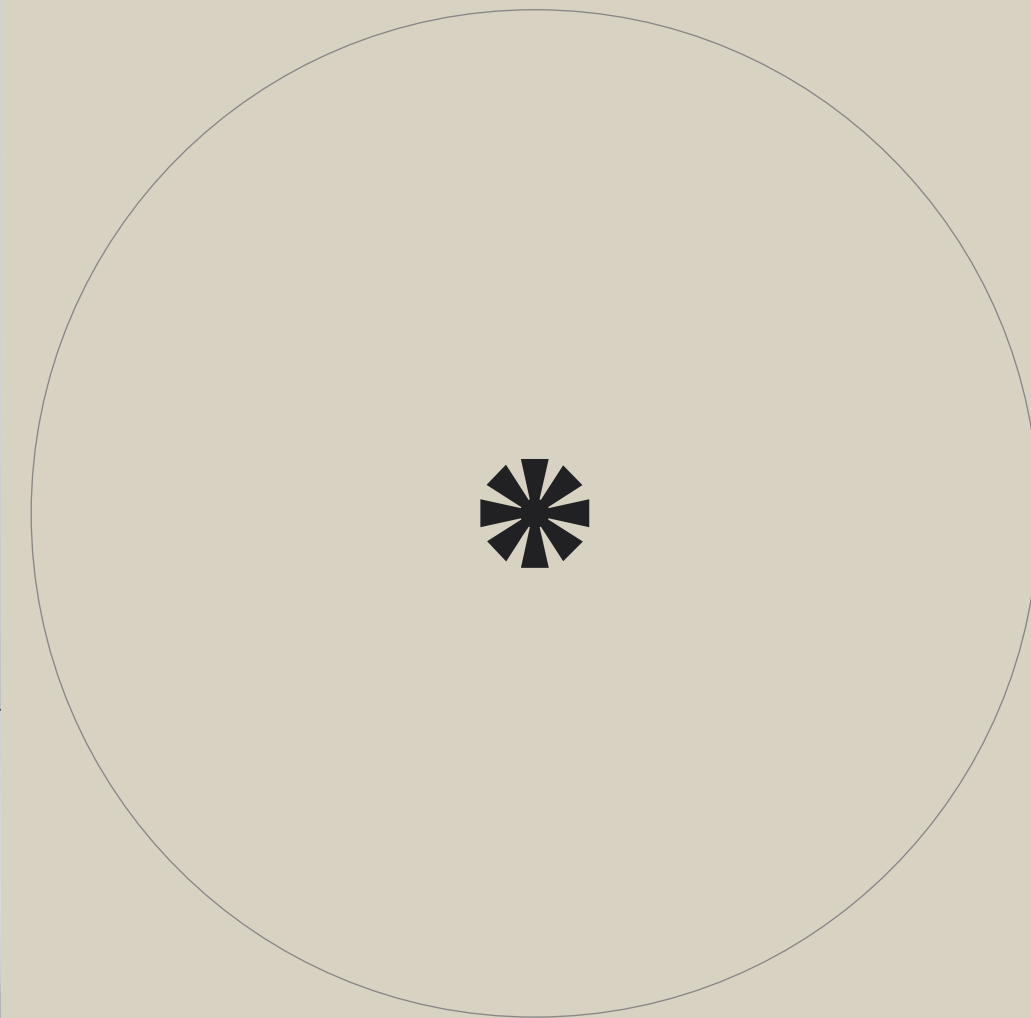



Six Senses Crans-Montana  
Crans-Montana, Switzerland

Designed by  
Betul Inci

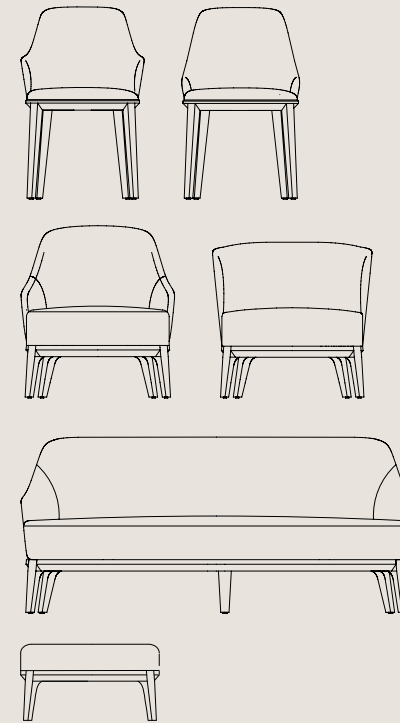

The Atlas Family is a testament to Parla Design's heritage; an element of comfort is added to a fine silhouette to continue our forefathers' spirit.

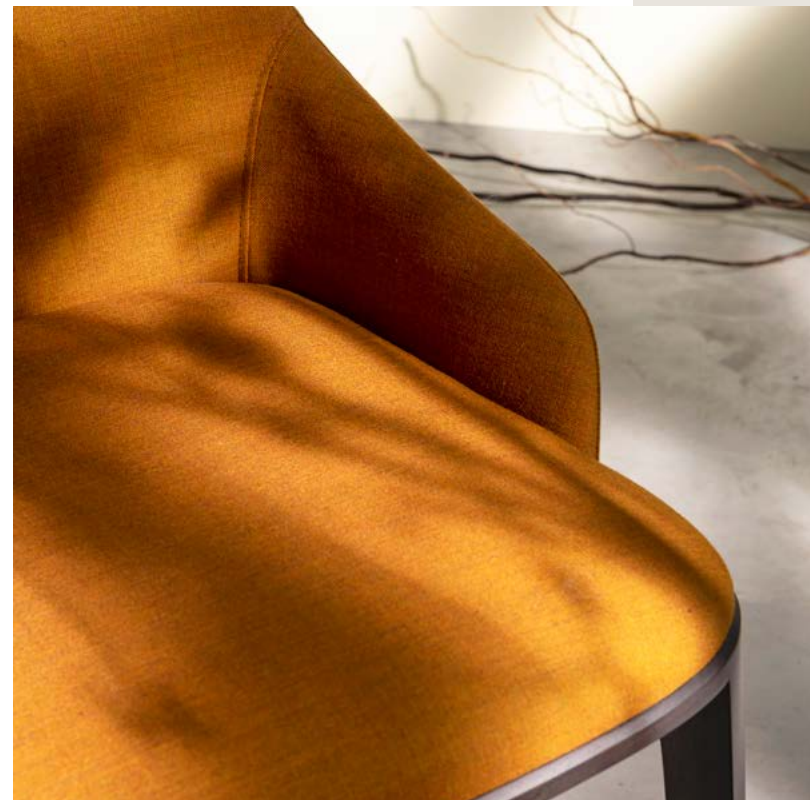

# Tofu

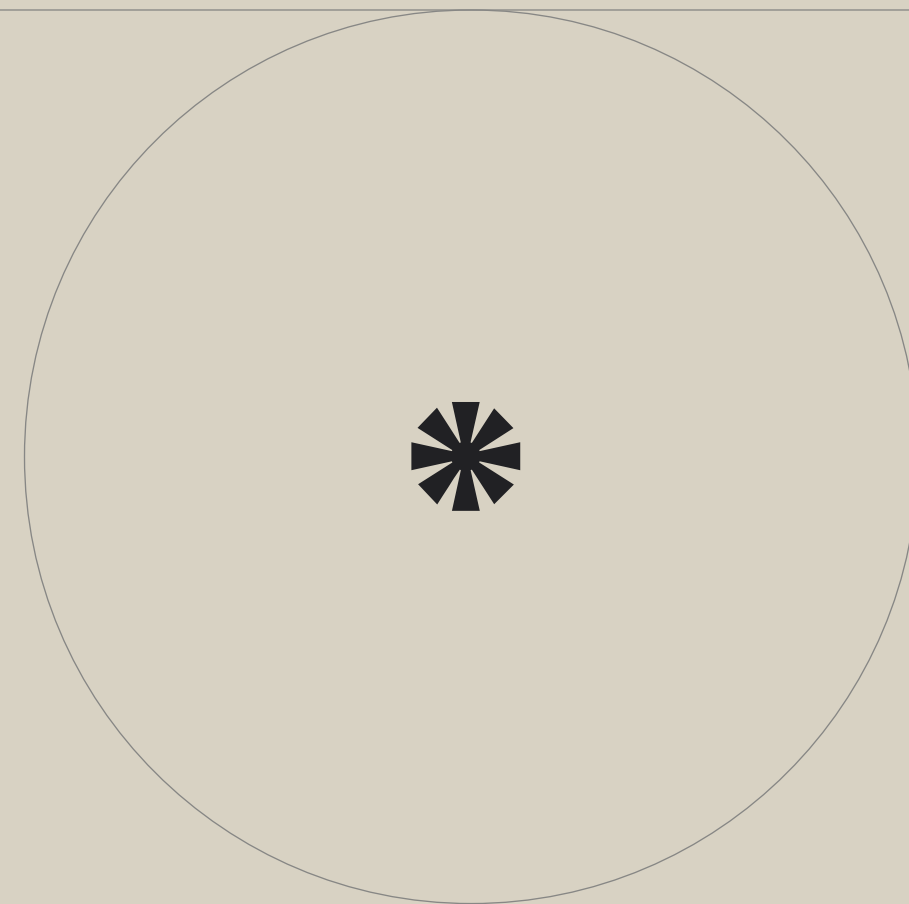



Lending both power and beauty to the pieces with its sculptural base, the Tofu family of tables are perfect for displaying the natural beauty of materials with a sculptural base that lends power to the piece. All pieces are available in exquisite stain colours and table top options such as marble, tinted glass and oak veneer.



Designed by  
Seda Yetkiner

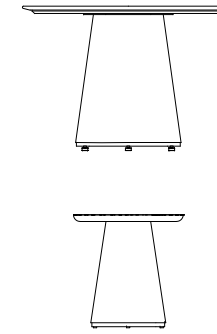

# Flento







Designed by  
Berrak Ilkcan Sener &  
Yasemin Derici Ceri

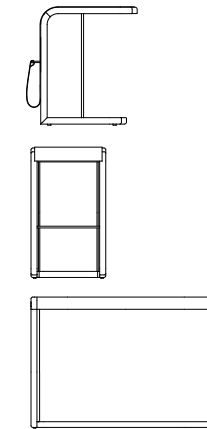

The Fleno Collection, which contains a variety of elements, makes a statement with sophisticated metal embellishment to a wooden base, softened and made inviting by gentle curves. The Fleno console, side table and stool, which perfectly complement one another, also work well alongside other styles, giving a fresh perspective to classic and sophisticated looks.



# Mawe





Designed by  
Yasemin Derici Ceri

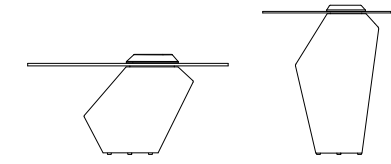

The sculptural, totemic Mawe Coffee Tables, are designed taking inspiration from the "Moai" sculptures in Ahu Akivi, Easter Island. Designer Yasemin Derici, who likes to look beyond borders for inspiration, wanted to bring together the solidity of marble with the fragility of glass, and the Moai sculptures sparked a light in her imagination. Alike their inspiration, the coffee tables offer a distinct look and a very precise finish.

# Rain





Designed by  
Buket Hoscan Bazman

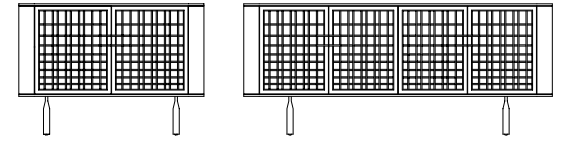

Our first set of sideboards, Rain offers contemporary luxury; perfectly proportioned, these sideboards encompass coloured steel, wood, and LED lighting, that are all then presented in a beautiful curved form.

# Details

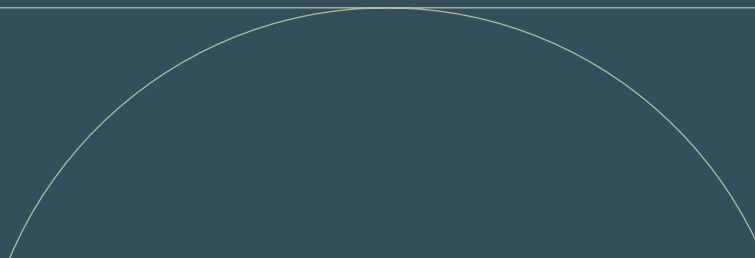
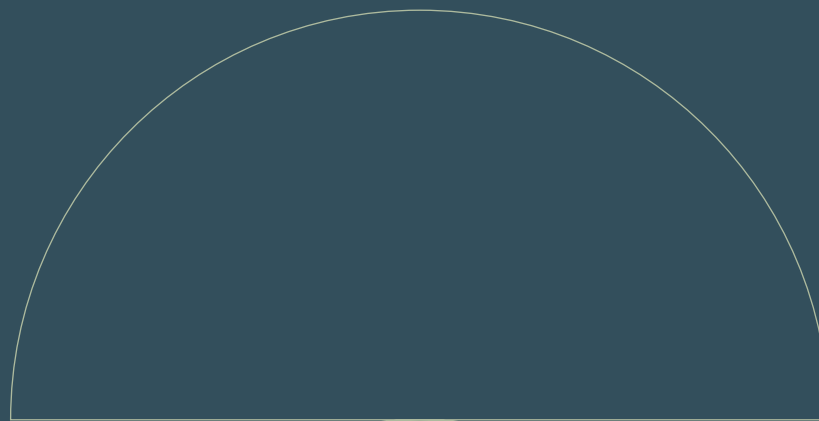
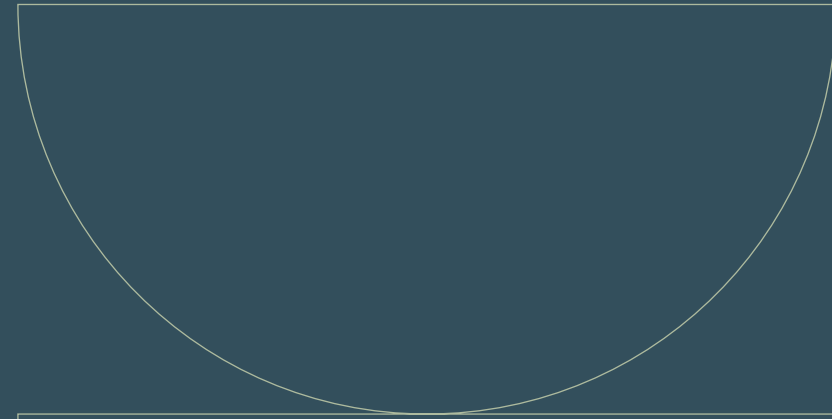

# Chairs



## Arven Chair

Product number: U010014  
Designed by Burcu Ozdamar

**Frame:** Plywood back and solid beech legs, metal, brass or stainless steel arms (with powder coated metal and coloured steel options)  
**Seat & Back:** Upholstered seat and back  
**Finish:** Available in multiple stain colours, arms available in Antique Brass, RAL or steel colours

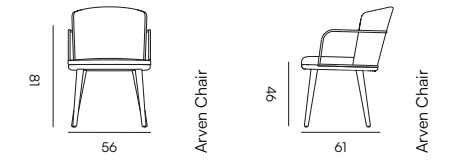

Product Number	Product Type	Dimensions
U0100253	Arven Chair (Brass)	W56 D61 H81 SH:46 cm
U0100252	Arven Chair (Cooured Steel)	W56 D61 H81 SH:46 cm

CHAIRS



## Arven L Chair

Product number: U010016  
Designed by Burcu Ozdamar

**Frame:** Plywood back and solid beech legs  
**Seat & Back:** Upholstered seat and back  
**Finish:** Available in multiple stain colours



## Atlas A Chair

Product number: U010021  
Designed by Betul Inci

**Frame:** Plywood back and solid beech legs  
**Seat & Back:** Upholstered seat and back  
**Finish:** Available in multiple stain colours

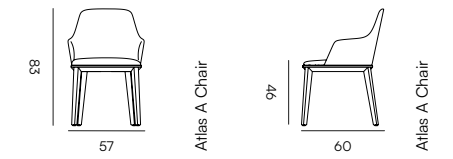

## Atlas Chair

Product number: U010022  
Designed by Betul Inci

**Frame:** Plywood back and solid beech legs  
**Seat & Back:** Upholstered seat and back  
**Finish:** Available in multiple stain colours

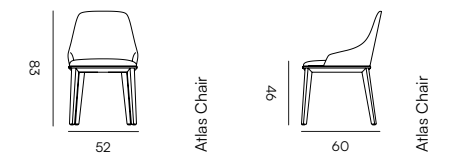

## Chia Chair

Product number: U010255  
Designed by Betul Inci

**Frame:** Plywood back and metal or stainless steel legs (with powder coated metal and coloured steel options)  
**Seat & Back:** Upholstered seat and back  
**Finish:** Available in RAL or steel colours

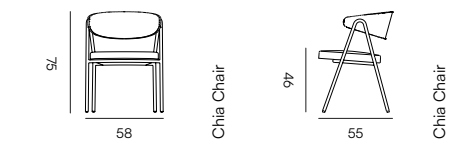

Product Number	Product Type	Dimensions
U0100294	Chia Chair (Coloured Steel)	W58 D55 H75 SH:46 cm

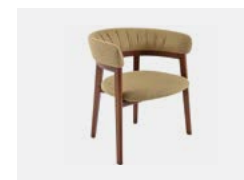

## Cora Chair

Product number: U01000345  
Designed by Seda Yetkiner

**Frame:** Moulded polyurethane back and solid ash structure  
**Seat & Back:** Upholstered seat and back  
**Finish:** Available in multiple stain colours

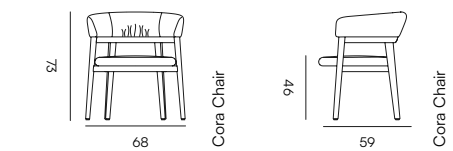



### Fau A Chair

Product number: U0100319  
Designed by Kilit Tasi Design Studio

**Frame:** Solid ash structure  
**Seat & Back:** Upholstered seat  
**Finish:** Available in multiple stain colours

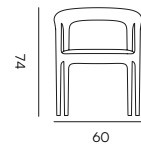

Fau A Chair

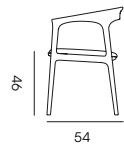

Fau A Chair



### Fau Chair

Product number: U01000335  
Designed by Kilit Tasi Design Studio

**Frame:** Solid ash structure  
**Seat & Back:** Upholstered seat  
**Finish:** Available in multiple stain colours

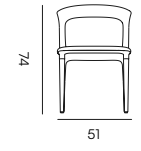

Fau Chair

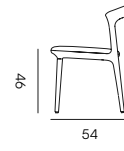

Fau Chair



### Gala Chair

Product number: U01000339  
Designed by Burcu Ozdamar

**Frame:** Ash veneer Plywood back and solid ash legs  
**Seat & Back:** Upholstered seat and back  
**Finish:** Available in multiple stain colours

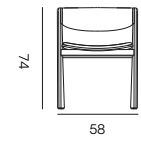

Gala Chair

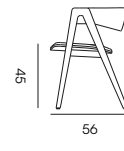

Gala Chair



### Gala V Chair

Product number: U0100286  
Designed by Burcu Ozdamar

**Frame:** Ash veneer Plywood back and solid ash legs  
**Seat & Back:** Upholstered seat and inner back  
**Finish:** Available in multiple stain colours

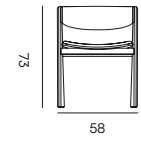

Gala V Chair

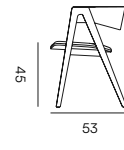

Gala V Chair



### Mate XL Chair

Product number: U010066  
Designed by Aysel Ilişik

**Frame:** Beech plywood back and seat, solid beech structure  
**Seat & Back:** Upholstered seat and back  
**Finish:** Available in multiple stain colours

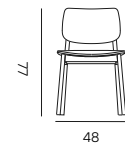

Mate XL Chair

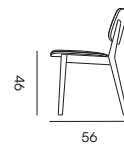

Mate XL Chair



### Mate XL V Chair

Product number: U010067  
Designed by Aysel Ilişik

**Frame:** Beech plywood back and seat, solid beech structure  
**Finish:** Available in multiple stain colours

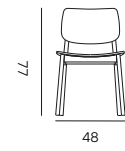

Mate XL V Chair

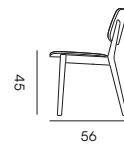

Mate XL V Chair







### Meru Chair

Product number: U010068  
Designed by Burcu Ozdamar

**Frame:** Powder coated metal structure with moulded polyurethane back  
**Seat & Back:** Upholstered seat and back  
**Finish:** Available in RAL colours

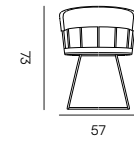

Meru Chair

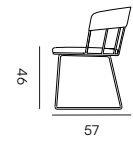

Meru Chair



### Meru L Chair

Product number: U010069  
Designed by Burcu Ozdamar

**Frame:** Powder coated metal structure with moulded polyurethane back and solid beech structure  
**Seat & Back:** Upholstered seat and back  
**Finish:** Available in multiple stain colours, back available in RAL colours

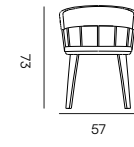

Meru L Chair

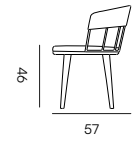

Meru L Chair



### Mod Chair

Product number: U010070  
Designed by Betul Inci

**Frame:** Moulded polyurethane body with solid beech legs  
**Seat & Back:** Upholstered seat and back  
**Finish:** Available in multiple stain colours

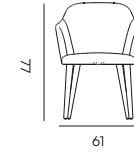

Mod Chair

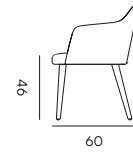

Mod Chair



### Mod RS Chair

Product number: U010130  
Designed by Betul Inci

**Frame:** Moulded polyurethane body with die-cast aluminium swivel base with castors  
**Seat & Back:** Upholstered seat and back  
**Finish:** Available polished chrome and black

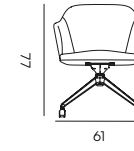

Mod RS Chair

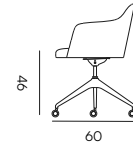

Mod RS Chair



### Mod S Chair

Product number: U010072  
Designed by Betul Inci

**Frame:** Moulded polyurethane body with die-cast aluminium swivel base  
**Seat & Back:** Upholstered seat and back  
**Finish:** Available polished chrome and black

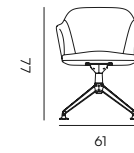

Mod S Chair

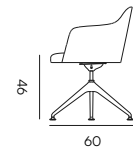

Mod S Chair



### Mod W Chair

Product number: U010074  
Designed by Betul Inci

**Frame:** Moulded polyurethane body with powder coated metal leg  
**Seat & Back:** Upholstered seat and back  
**Finish:** Available in RAL colours

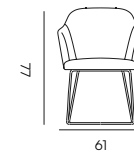

Mod W Chair

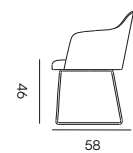

Mod W Chair



## Nigiri Chair

Product number: U0100282  
Designed by Betül İnci

**Frame:** Solid ash structure  
**Seat & Back:** Upholstered seat and back  
**Finish:** Available in multiple stain colours

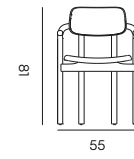

Nigiri Chair

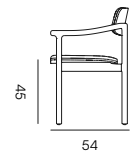

Nigiri Chair



## Oyster Chair

Product number: U0100284  
Designed by Enis Altinkaynak

**Frame:** Plywood back and solid ash legs  
**Seat & Back:** Upholstered seat and back  
**Finish:** Available in multiple stain colours

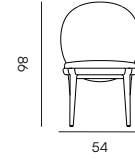

Oyster Chair

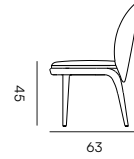

Oyster Chair



## Oyster W Chair

Product number: U0100268  
Designed by Enis Altinkaynak

**Frame:** Plywood back and metal or stainless steel legs,  
(with powder coated metal and coloured steel options)  
**Seat & Back:** Upholstered seat and back  
**Finish:** Available in RAL or steel colours

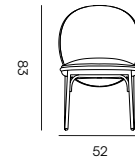

Oyster W Chair

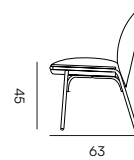

Oyster W Chair

Product Number	Product Type	Dimensions
U0100267	Oyster W Chair (Coloured Steel)	W52 D63 H83 SH:45 cm



## Oyster WA Chair

Product number: U0100311  
Designed by Enis Altinkaynak

**Frame:** Plywood back and metal or stainless steel legs,  
(with powder coated metal and coloured steel options)  
**Seat & Back:** Upholstered seat and back  
**Finish:** Available in RAL or steel colours

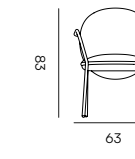

Oyster WA Chair

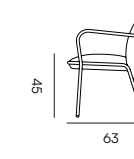

Oyster WA Chair

Product Number	Product Type	Dimensions
U0100322	Oyster WA Chair (Coloured Steel)	W63 D63 H83 SH:45 cm



## Palm A Chair

Product number: U0100310  
Designed by Jean-Michel Wilmotte

**Frame:** Powder coated metal structure  
**Seat & Back:** Fix upholstered seat

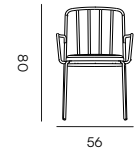

Palm A Chair

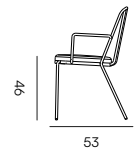

Palm A Chair



## Palm Chair

Product number: U0100314  
Designed by Jean-Michel Wilmotte

**Frame:** Powder coated metal structure  
**Seat & Back:** Fix upholstered seat

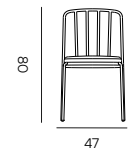

Palm Chair

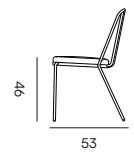

Palm Chair





### Palm XA Chair

Product number: U0100326  
Designed by Jean-Michel Wilmotte

**Frame:** Powder coated metal structure  
**Seat & Back:** Fix upholstered seat and back

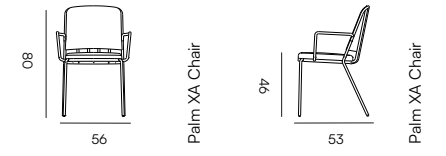

### Palm X Chair

Product number: U0100316  
Designed by Jean-Michel Wilmotte

**Frame:** Powder coated metal structure with armrest  
**Seat & Back:** Fix upholstered seat and back

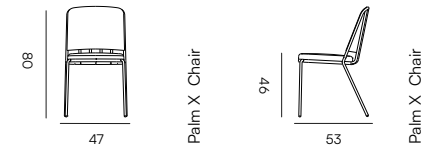

### Remus Chair

Product number: U010093  
Designed by David Fox

**Frame:** Moulded polyurethane body with solid beech legs  
**Seat & Back:** Upholstered seat and back  
**Finish:** Available in multiple stain colours

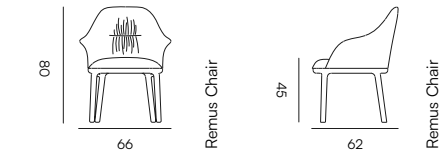

### Remus S Chair

Product number: U010095  
Designed by David Fox

**Frame:** Moulded polyurethane body with solid beech legs  
**Seat & Back:** Upholstered seat and back  
**Finish:** Available in multiple stain colours

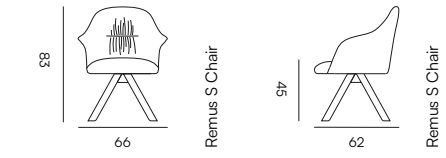

### Ren Chair

Product number: U010250  
Designed by Betul Inci

**Frame:** Plywood back and solid beech legs  
**Seat & Back:** Upholstered seat and back  
**Finish:** Available in multiple stain colours

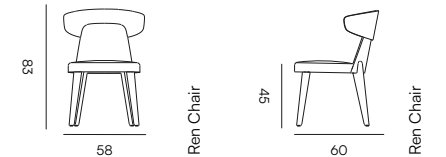

### Ren P Chair

Product number: U0100260  
Designed by Betul Inci

**Frame:** Plywood back and solid beech legs  
**Seat & Back:** Upholstered seat and back  
**Finish:** Available in multiple stain colours

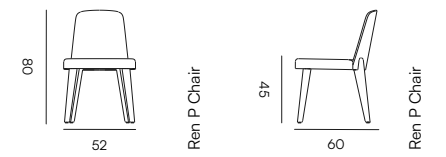



## Rimo Chair

Product number: U0100256  
Designed by Berrak Ilkcan Sener

**Frame:** Plywood back and metal or stainless steel legs  
(with powder coated metal and coloured steel options)  
**Seat & Back:** Upholstered seat and back  
**Finish:** Available in RAL or steel colours

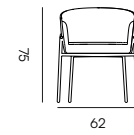

62

Rimo Chair

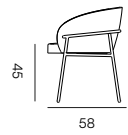

58

Rimo Chair

Product Number	Product Type	Dimensions
U0100269	Rimo Chair (Coloured Steel)	W62 D58 H75 SH:45 cm



## Venus A Chair

Product number: U010141  
Designed by Betul Inci

**Frame:** Solid beech structure  
**Seat & Back:** Upholstered seat and back  
**Finish:** Available in multiple stain colours

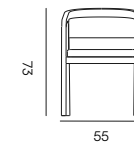

55

Venus A Chair

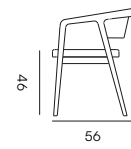

46

56

Venus A Chair



## Sabien A Chair

Product number: U010096  
Designed by David Fox

**Frame:** Plywood back and solid beech legs  
**Seat & Back:** Upholstered quilted seat and back  
**Finish:** Available in multiple stain colours

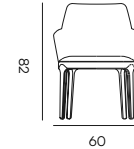

82

60

Sabien A Chair

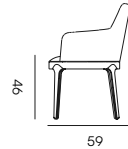

46

59

Sabien A Chair



## Venus Chair

Product number: U010125  
Designed by Betul Inci

**Frame:** Solid beech structure  
**Seat & Back:** Upholstered seat and back  
**Finish:** Available in multiple stain colours

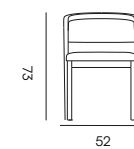

73

52

Venus Chair

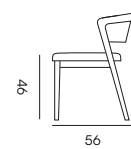

46

56

Venus Chair



## Sabien Chair

Product number: U010097  
Designed by David Fox

**Frame:** Plywood back and solid beech legs  
**Seat & Back:** Upholstered quilted seat and back  
**Finish:** Available in multiple stain colours

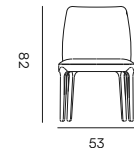

82

53

Sabien Chair

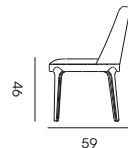

46

59

Sabien Chair



## Stella Chair

Product number: U010107  
Designed by Betul Inci

**Frame:** Ash veneer Plywood back and solid beech legs  
**Seat & Back:** Upholstered seat and back  
**Finish:** Available in multiple stain colours

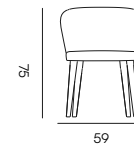

52

59

Stella Chair

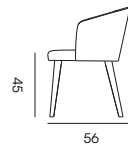

45

56

Stella Chair



## Stella V Chair

Product number: U010109  
Designed by Betul Inci

**Frame:** Oak veneer plywood back and solid beech legs  
**Seat & Back:** Upholstered seat and back  
**Finish:** Available in multiple stain colours

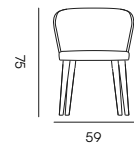

52

59

Stella V Chair

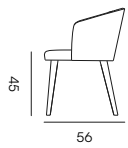

45

56

Stella V Chair



## Stella W Chair

Product number: U010111  
Designed by Betul Inci

**Frame:** Plywood back and powder coated metal leg  
**Seat & Back:** Upholstered seat and back  
**Finish:** Available in RAL colours

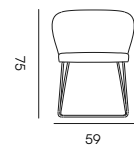

52

59

Stella W Chair

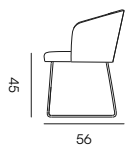

45

56

Stella W Chair

# Armchairs



## Atlas Armchair

Product number: U020004  
Designed by Betül İnci

**Frame:** Plywood and solid beech structure, solid beech leg  
**Seat & Back:** Upholstered seat and back  
**Finish:** Available in multiple colours

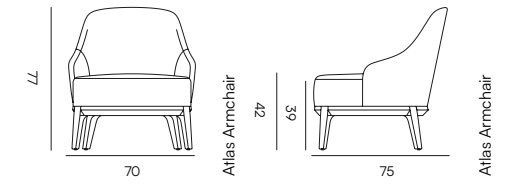

ARMCHAIRS



## Atlas V Armchair

Product number: U020007  
Designed by Betül İnci

**Frame:** Plywood and solid beech structure, solid beech leg  
**Seat & Back:** Upholstered seat and back  
**Finish:** Available in multiple colours

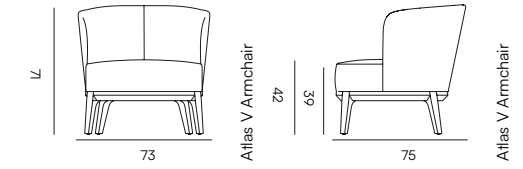

## Bloom Club Armchair

Product number: U0200112  
Designed by Betül İnci

**Frame:** Plywood and solid beech structure (with 360° swivel base option)  
**Seat & Back:** Upholstered seat and back cushions

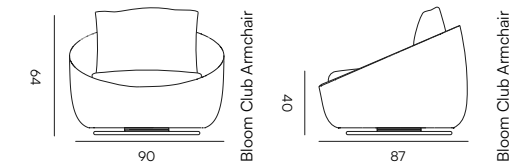

## Cora Armchair

Product number: U020000159  
Designed by Seda Yetkiner

**Frame:** Moulded polyurethane back and solid ash structure  
**Seat & Back:** Upholstered seat and back  
**Finish:** Available in multiple colours

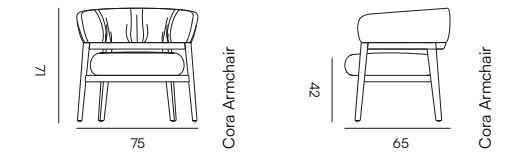

## Estival Armchair

Product number: U020024  
Designed by Parla Studio

**Frame:** Plywood and solid beech structure, powder coated metal base  
**Seat & Back:** Upholstered seat, back and cushions  
**Finish:** Available in RAL colours

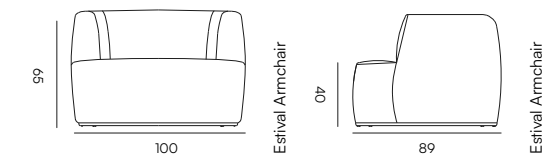

## Eve Wing Back Armchair

Product number: U020025  
Designed by Erden Dereli

**Frame:** Plywood and solid beech structure and solid beech legs  
**Seat & Back:** Upholstered seat and back  
**Finish:** Available in multiple stain colours

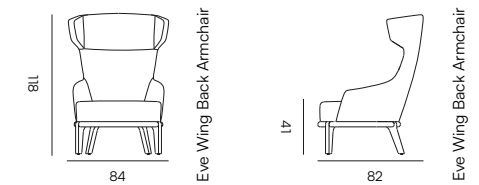



### Eve Wing Back S Armchair

Product number: U0200147  
Designed by Erden Dereli

**Frame:** Moulded polyurathane body with die-cast aluminium swivel base  
**Seat & Back:** Upholstered seat and back  
**Finish:** Available polished chrome and black

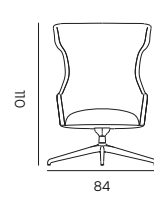

Eve Wing Back S Armchair

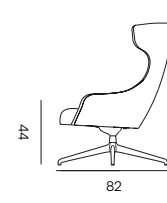

Eve Wing Back S Armchair



### Goba Armchair

Product number: U020032  
Designed by Esin Sozer Kalender / Arketipo Design

**Frame:** Solid beech structure  
**Seat & Back:** Upholstered seat and back cushions  
**Finish:** Available in multiple stain colours

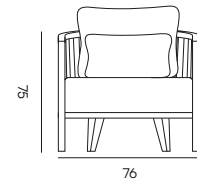

Goba Armchair

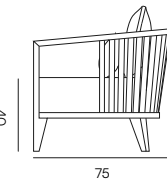

Goba Armchair



### Hew Armchair

Product number: U0200148  
Designed by Goodrich

**Frame:** Plywood structure and solid ash legs  
**Seat & Back:** Upholstered seat and back  
**Finish:** Available in multiple stain colours

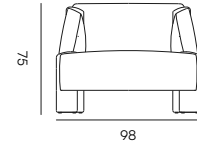

Hew Armchair

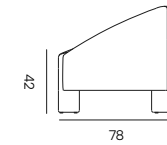

Hew Armchair



### Hug Armchair

Product number: U0200131  
Designed by Betül İnci

**Frame:** Plywood and solid beech structure, oak veneered base with solid wood edge  
**Seat & Back:** Upholstered seat and back  
**Finish:** Available in multiple stain colours

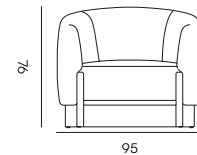

Hug Armchair

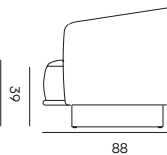

Hug Armchair



### Loop Armchair

Product number: U020000160  
Designed by Goodrich

**Frame:** Plywood structure  
**Seat & Back:** Upholstered seat and back

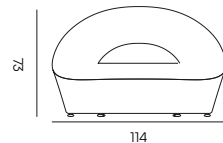

Loop Armchair

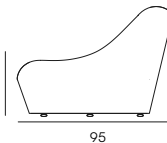

Loop Armchair



### Moose Armchair

Product number: U0200121  
Designed by Deniz Albayrak

**Frame:** Solid ash back structure, ash veneer base  
**Seat & Back:** Upholstered seat  
**Finish:** Available in multiple stain colours

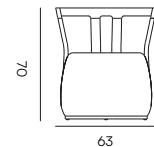

Moose Armchair

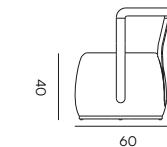

Moose Armchair

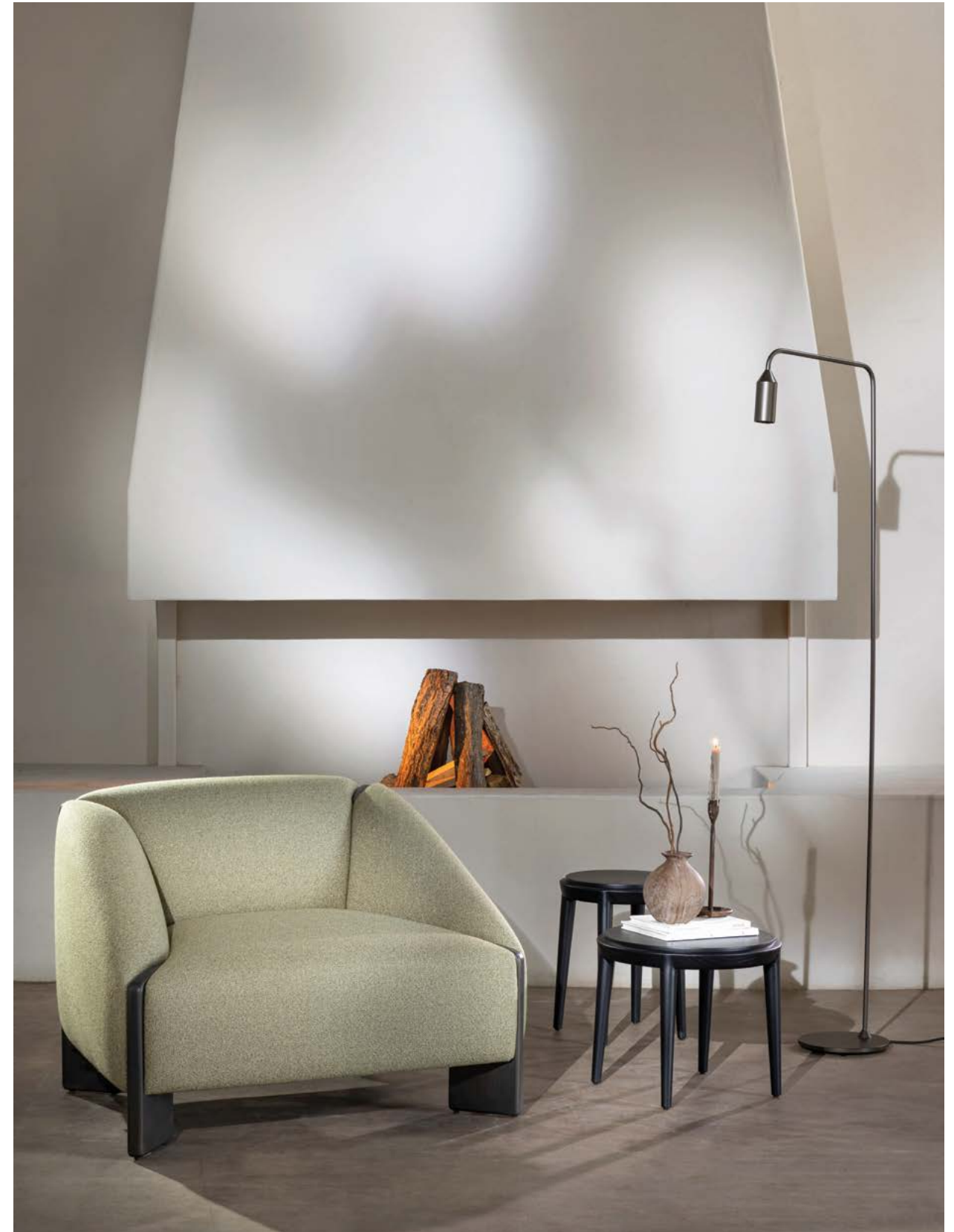



### Nigiri Armchair

Product number: U02000161  
Designed by Betul Inci



**Frame:** Solid ash structure  
**Seat & Back:** Upholstered seat and back  
**Finish:** Available in multiple stain colours

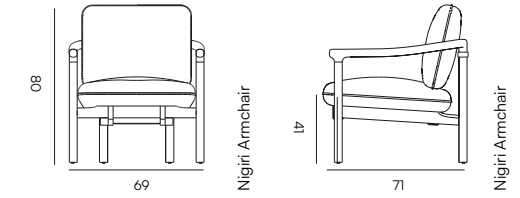

ARMCHAIRS



### Oyster W Armchair

Product number: U0200111  
Designed by Enis Altinkaynak

**Frame:** Plywood back and metal or stainless steel legs (with powder coated metal and coloured steel options)  
**Seat & Back:** Upholstered seat and back  
**Finish:** Available in RAL or steel colours

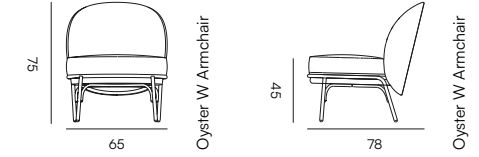

Product Number	Product Type	Dimensions
U0200110	Oyster W Armchair (Coloured Steel)	W65 D78 H75 SH:46 cm



### Padova Armchair

Product number: U020055  
Designed by Betul Inci

**Frame:** Plywood structure, oak veneer plywood back and base (with 360° swivel base option)  
**Seat & Back:** Upholstered seat and inner back  
**Finish:** Available in multiple stain colours

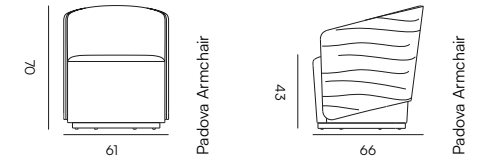

Product Number	Product Type	Dimensions
U0200098	Padova S Armchair (Swivel)	W61 D66 H70 SH:43 cm



### Padova U Armchair

Product number: U0200103  
Designed by Betul Inci

**Frame:** Moulded polyurethane back and plywood structure with natural oak veneer base (with 360° swivel base option)  
**Seat & Back:** Upholstered seat and back  
**Finish:** Available in multiple stain colours

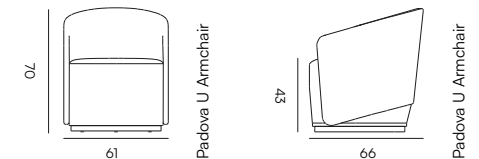

Product Number	Product Type	Dimensions
U0200104	Padova U S Armchair (Swivel)	W61 D66 H70 SH:43 cm



### Remus Armchair

Product number: U020070  
Designed by David Fox

**Frame:** Moulded polyurethane body, solid beech legs  
**Seat & Back:** Upholstered seat and back  
**Finish:** Available in multiple colours

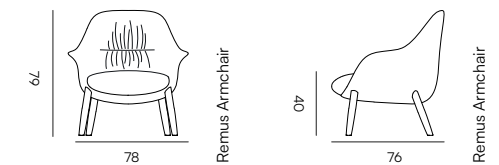

### Remus S Armchair

Product number: U020090  
Designed by David Fox

**Frame:** Moulded polyurethane body with die-cast aluminium swivel base with castors  
**Seat & Back:** Upholstered seat and back  
**Finish:** Available polished chrome and black

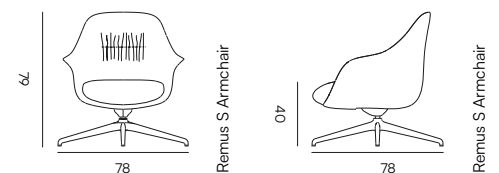



### Rimo Armchair

Product number: U020075  
Designed by Berrak Ilkcan Sener

**Frame:** Moulded polyurethane body and metal or stainless steel legs (with powder coated metal and coloured steel options)  
**Seat & Back:** Upholstered seat and back  
**Finish:** Available in RAL or steel colours

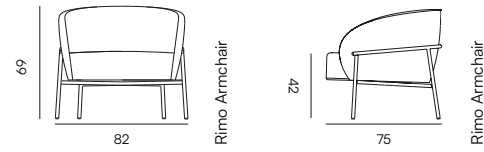

Product Number	Product Type	Dimensions
U0200106	Rimo Armchair (Coloured Steel)	W82 D75 H69 SH:42 cm



### Xaylon Armchair

Product number: U0200135  
Designed by David Fox

**Frame:** Moulded polyurethane body and solid beech legs  
**Seat & Back:** Upholstered seat and back  
**Finish:** Available in multiple stain colours

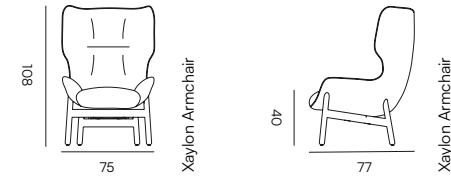

### Xaylon S Armchair

Product number: U0200144  
Designed by David Fox

**Frame:** Moulded polyurethane body with die-cast aluminium swivel base  
**Seat & Back:** Upholstered seat and back  
**Finish:** Available polished chrome and black

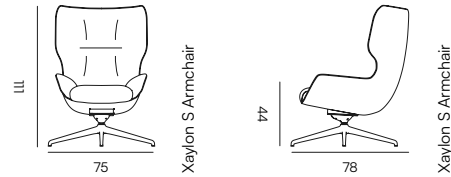

### Xaylon W Armchair

Product number: U0200128  
Designed by David Fox

**Frame:** Moulded polyurethane body and metal or stainless steel legs (with powder coated and coloured steel options)  
**Seat & Back:** Upholstered seat and back  
**Finish:** Available in RAL or steel colours

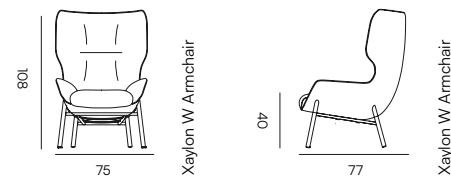

Product Number	Product Type	Dimensions
U0200134	Xaylon W Armchair (Coloured Steel)	W75 D77 H108 SH:40 cm





# Stools & Poufs



## Atlas Pouf

Product number: U070002  
Designed by Betül İnci

**Frame:** Plywood structure and solid beech legs  
**Seat & Back:** Upholstered seat  
**Finish:** Available in multiple stain colours

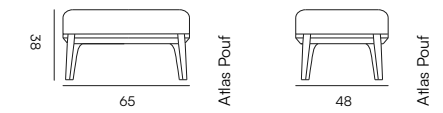

## Hew Bench

Product number: U11000035  
Designed by Goodrich

**Frame:** Plywood structure and solid ash legs  
**Seat:** Upholstered seat  
**Finish:** Available in multiple stain colours

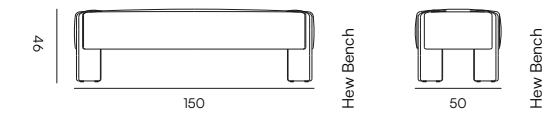

## Hug Bench

Product number: U08002112  
Designed by Betül İnci

**Frame:** Plywood and solid beech structure, oak veneered base with solid wood edge  
**Seat:** Upholstered seat  
**Finish:** Available in multiple stain colours

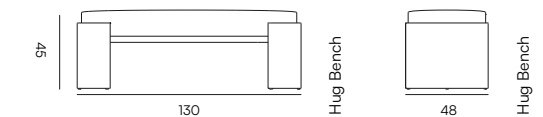

## Hug Pouf

Product number: U07000024  
Designed by Betül İnci

**Frame:** Plywood and solid beech structure, oak veneered base with solid wood edge  
**Seat:** Upholstered seat  
**Finish:** Available in multiple stain colours



Product Number	Product Type	Dimensions
U07000025	Hug Pouf Q64	Dia64 H39



## Hug Stool

Product number: U07000026  
Designed by Betül İnci

**Frame:** Plywood and solid beech structure, oak veneered base with solid wood edge  
**Seat:** Upholstered seat  
**Finish:** Available in multiple stain colours

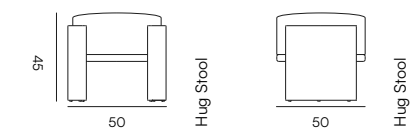

## London Pouf

Product number: U070005  
Designed by Burcu Özdamar

**Frame:** Plywood and solid beech structure, oak veneer base and powder coated metal legs  
**Seat:** Upholstered seat  
**Finish:** Base available in natural walnut or oak veneer with multiple stain colours, legs available in steel or RAL colours

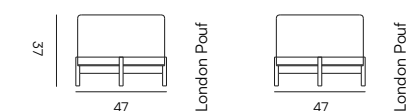

Product Number	Product Type	Dimensions
U0700020	London Pouf (Coloured Steel)	W47 D47 H37 cm



### Loop Pouf Q120

Product number: U070000028  
Designed by Goodrich

**Frame:** Plywood structure  
**Seat:** Upholstered seat

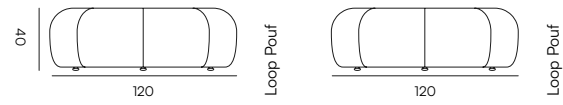

### Remus Pouf

Product number: U0700009  
Designed by David Fox

**Frame:** Plywood structure and solid beech legs  
**Seat & Back:** Upholstered seat  
**Finish:** Available in multiple stain colours



### Loop Pouf Q180

Product number: U070000029  
Designed by Goodrich

**Frame:** Plywood structure  
**Seat:** Upholstered seat



### Rocks Pouf

Designed by Deniz Albayrak

**Frame:** Plywood structure  
**Seat:** Upholstered seat

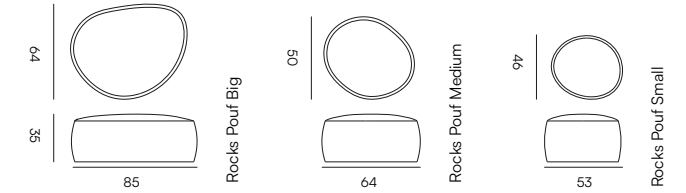

Product Number	Product Type	Dimensions
U070010	Rocks Pouf Big	W85 D64 H35
U070011	Rocks Pouf Medium	W64 D50 H35
U070012	Rocks Pouf Small	W53 D46 H35



### Loop Pouf 160x120

Product number: U070000030  
Designed by Goodrich

**Frame:** Plywood structure  
**Seat:** Upholstered seat

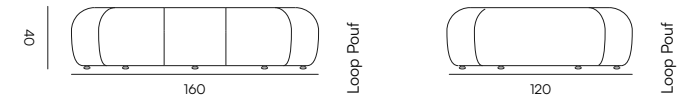

### Nigiri Bench

Product number: U080021111  
Designed by Betül İnci

**Frame:** Solid ash structure  
coloured stainless steel footrest  
**Seat:** Upholstered seat  
**Finish:** Available in multiple stain colours

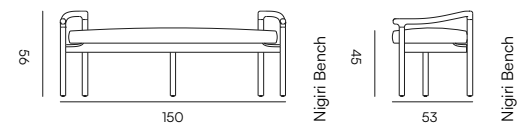

### Palm A Bench

Product number: U1100013  
Designed by Jean-Michel Wilmotte

**Frame:** Powder coated metal structure with armrest  
**Seat & Back:** Fix upholstered seat

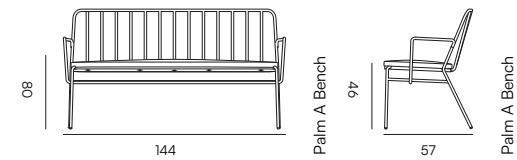

### Palm XA Bench

Product number: U0802111  
Designed by Jean-Michel Wilmotte

**Frame:** Powder coated metal structure with armrest  
**Seat & Back:** Fix upholstered seat & Back

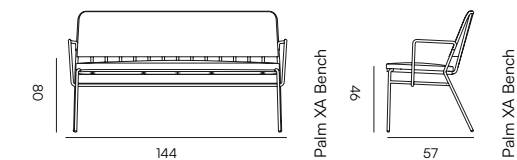

# Bar Stools



## Arven Bar Stool

Product number: U060002  
Designed by Burcu Ozdamar

**Frame:** Plywood back and solid beech legs, powder coated metal arm & footrest  
**Seat & Back:** Upholstered seat and back  
**Finish:** Available in multiple stain colours, arm & footrest are available in in steel or RAL colours  
\*Available in Counter Height

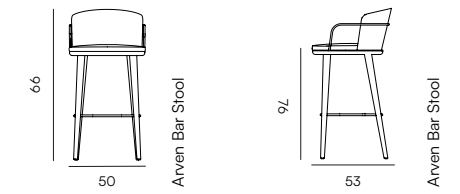

Product Number	Product Type	Dimensions
U0600053	Arven Bar Stool (Brass)	W50 D53 H99 SH:76 cm
U0600054	Arven Bar Stool (Coloured Steel)	W50 D53 H99 SH:76 cm
U0600061	Arven Counter Stool	W50 D53 H88 SH:65 cm
U0600062	Arven Counter Stool (Brass)	W50 D53 H88 SH:65 cm
U0600063	Arven Counter Stool (Coloured Steel)	W50 D53 H88 SH:65 cm



## Arven L Bar Stool

Product number: U060003  
Designed by Burcu Ozdamar

**Frame:** Plywood back and solid beech legs, powder coated footrest  
**Seat & Back:** Upholstered seat and back  
**Finish:** Available in multiple stain colours, footrest is available in steel or RAL colours  
\*Available in Counter Height

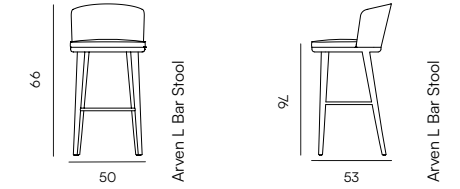

Product Number	Product Type	Dimensions
U0600052	Arven L Bar Stool (Brass)	W50 D53 H99 SH:76 cm
U0600051	Arven L Bar Stool (Col. Steel)	W50 D53 H99 SH:76 cm
U0600065	Arven L Counter Stool	W50 D53 H88 SH:65 cm
U0600066	Arven L Counter Stool (Brass)	W50 D53 H88 SH:65 cm
U0600067	Arven L Counter Stool (Col. Steel)	W50 D53 H88 SH:65 cm



## Bloom Bar Stool

Product number: U060004  
Designed by Betul Inci

**Frame:** Plywood structure, powder coated metal leg  
**Seat & Back:** Upholstered seat and back  
**Finish:** Available in RAL colours  
\*Available in Counter Height



Product Number	Product Type	Dimensions
U0600098	Bloom Counter Stool	W53 D50 H81 SH:65 cm



## Bloom WA Bar Stool

Product number: U060007  
Designed by Betul Inci

**Frame:** Plywood structure and solid beech legs, powder coated metal footrest  
**Seat & Back:** Upholstered seat and back  
**Finish:** Available in multiple stain colours, footrest is available in brass, steel or RAL colours  
\*Available in Counter Height

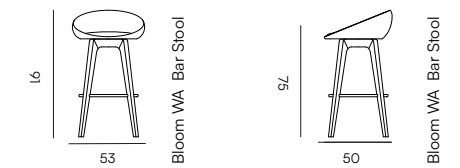

Product Number	Product Type	Dimensions
U0600050	Bloom WA Bar Stool (Brass)	W53 D50 H91 SH:75 cm
U0600049	Bloom WA Bar Stool (Col. Steel)	W53 D50 H91 SH:75 cm



### Chia Bar Stool

Product number: U0600046  
Designed by Betül İnci

**Frame:** Plywood back and powder coated metal legs  
**Seat & Back:** Upholstered seat and back  
**Finish:** Available in steel or RAL colours  
\*Available in Counter Height

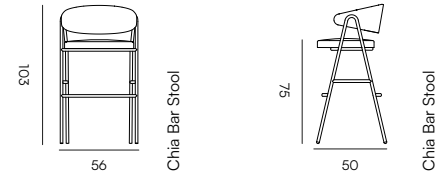

Product Number	Product Type	Dimensions
U0600075	Chia Bar Stool (Coloured Steel)	W56 D50 H103 SH:75 cm
U0600099	Chia Counter Stool	W56 D50 H93 SH:65 cm
U600100	Chia Counter Stool (Col. Steel)	W56 D50 H93 SH:65 cm



### Flento Bar Stool

Product number: U0600060  
Designed by Berrak İlkan Sener & Yasemin Derici

**Frame:** Solid ash and coloured stainless steel legs, coloured stainless steel footrest  
**Seat:** Upholstered genuine leather seat  
**Finish:** Available in steel colours, legs available in multiple stain colours, top available in Relax Series genuine leather colours

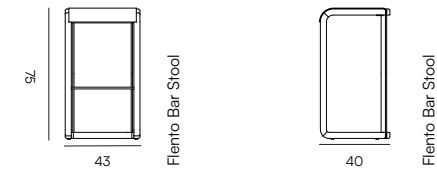

Product Number	Product Type	Dimensions
U06000134	Gala Counter Stool	W58 D56 H90 SH:65 cm



### Gala Bar Stool

Product number: U06000132  
Designed by Burcu Ozdamar

**Frame:** Upholstered Plywood back and solid ash legs  
**Seat & Back:** Upholstered seat and back  
**Finish:** Available in multiple stain colours  
\*Available in Counter Height

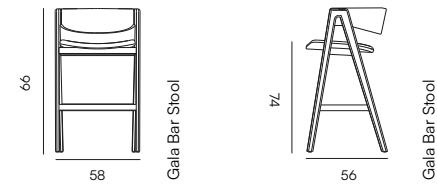

Product Number	Product Type	Dimensions
U06000135	Gala V Counter Stool	W58 D56 H90 SH:65 cm



### Gala V Bar Stool

Product number: U06000116  
Designed by Burcu Ozdamar

**Frame:** Ash veneer Plywood back and solid ash legs  
**Seat & Back:** Upholstered seat and back  
**Finish:** Available in multiple stain colours  
\*Available in Counter Height

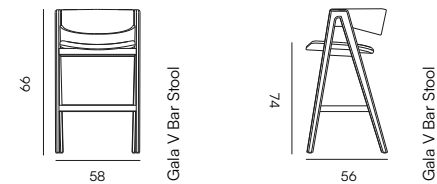

### Mate Bar Stool

Product number: U060019  
Designed by Aysel İlişik

**Frame:** Beech veneer plywood back and solid beech structure  
**Seat & Back:** Upholstered seat and back  
**Finish:** Available in multiple stain colours  
\*Available in Counter Height

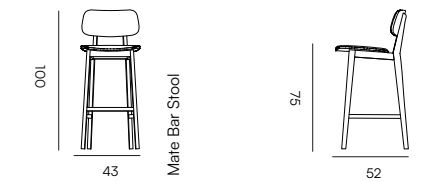

Product Number	Product Type	Dimensions
U0600074	Mate Counter Stool	W43 D52 H90 SH:65 cm

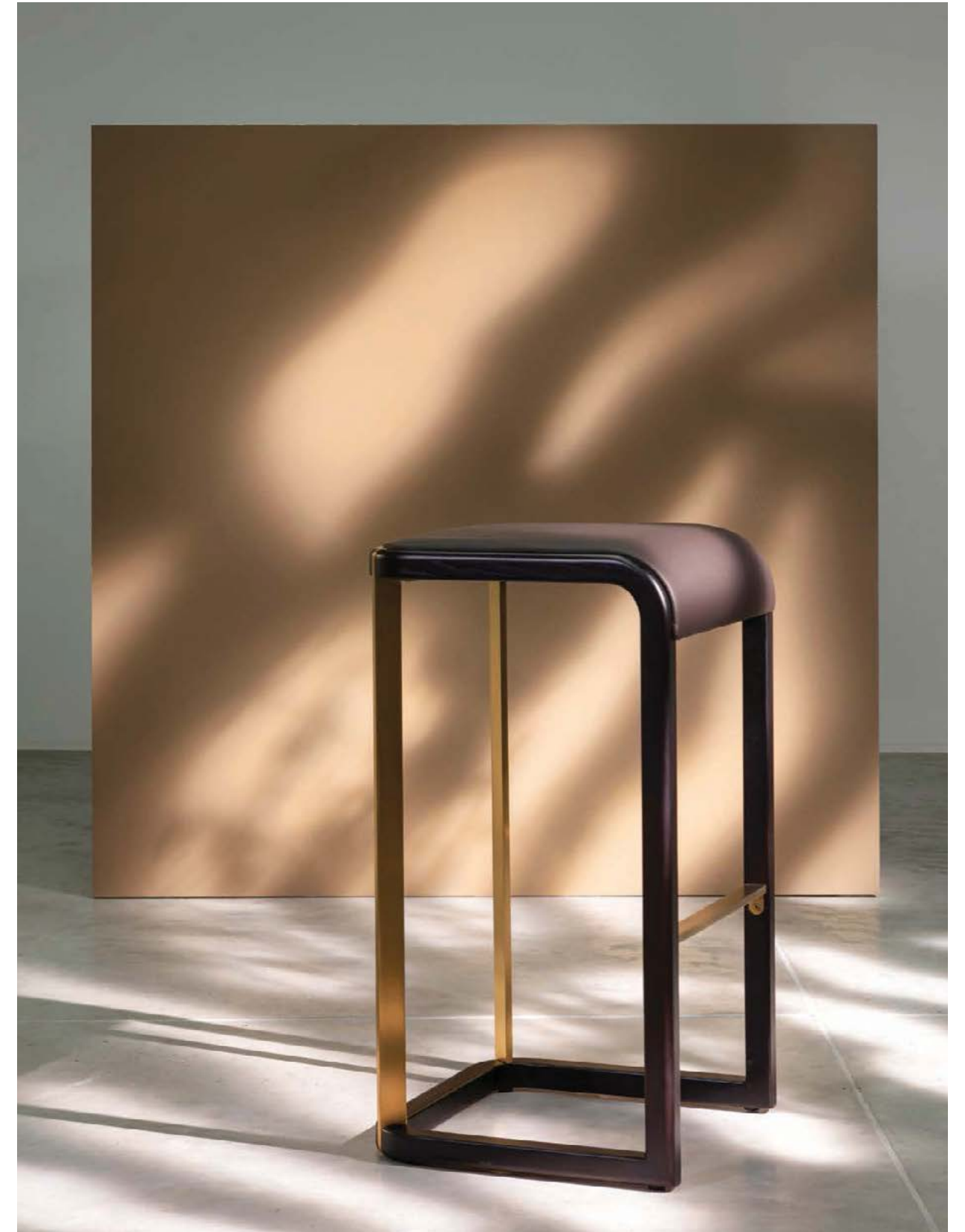



### Mate V Bar Stool

Product number: U060019  
Designed by Aysel Ilişik

**Frame:** Beech plywood back and seat, solid beech structure  
**Finish:** Available in multiple stain colours  
\*Available in Counter Height

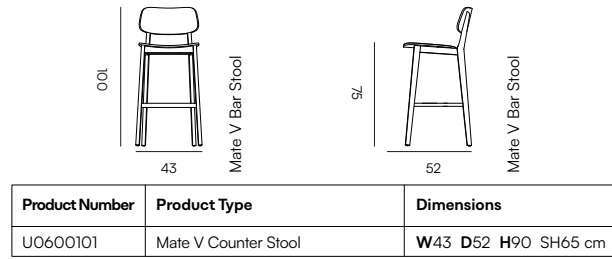

### Palm Bar Stool

Product number: U0600088  
Designed by Jean-Michel Wilmotte

**Frame:** Powder coated metal structure  
**Seat & Back:** Fix upholstered seat  
**Finish:** \*Available in Counter Height

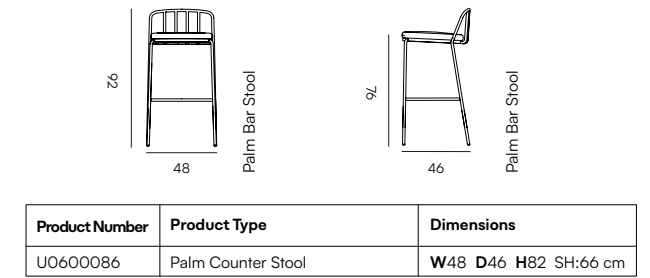

### Meru Bar Stool

Product number: U060021  
Designed by Burcu Ozdamar

**Frame:** Moulded polyurethane back with powder coated metal structure  
**Seat & Back:** Upholstered seat and back  
**Finish:** Available in RAL colours

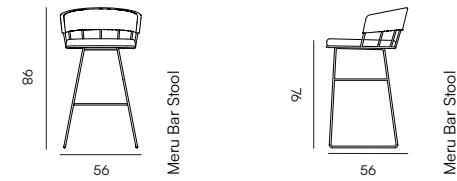

### Sabien A Bar Stool

Product number: U0600056  
Designed by David Fox

**Frame:** Plywood back and solid beech legs  
**Seat & Back:** Upholstered quilted seat and back  
**Finish:** Available in multiple stain colours  
\*Available in Counter Height

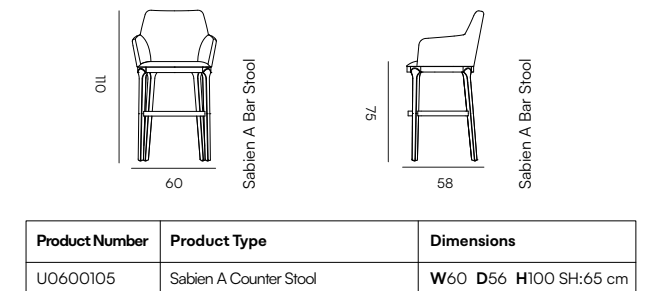

### Meru L Bar Stool

Product number: U060022  
Designed by Burcu Ozdamar

**Frame:** Moulded polyurethane back with powder coated metal structure, footrest and solid beech legs  
**Seat & Back:** Upholstered seat and back  
**Finish:** Available in multiple stain colors, back and footrest are available in RAL colours  
\*Available in Counter Height

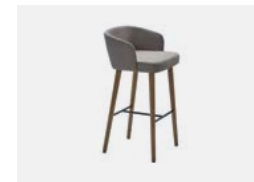
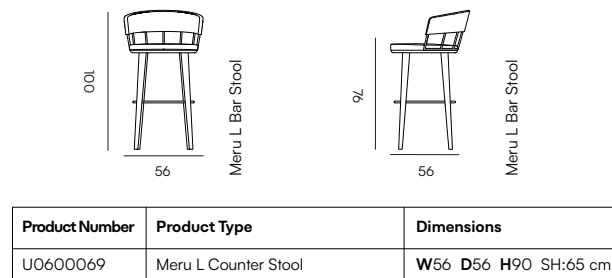

### Stella Bar Stool

Product number: U060032  
Designed by Betül İnci

**Frame:** Plywood back and solid beech legs, powder coated metal footrest  
**Seat & Back:** Upholstered seat and back  
**Finish:** Available in multiple stain colours  
Footrest available in brass, steel or RAL colours  
\*Available in Counter Height

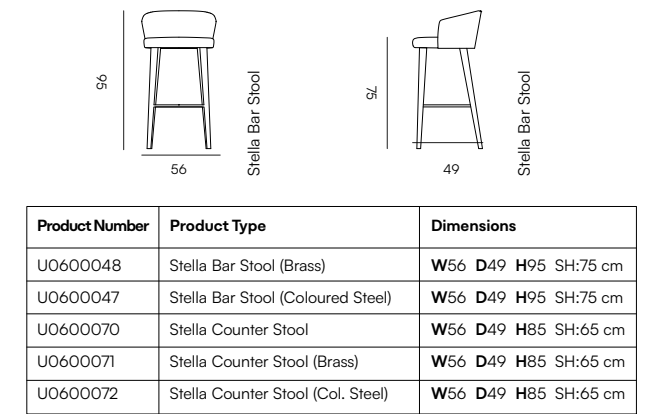

### Nigiri Bar Stool

Product number: U0600082  
Designed by Betül İnci

**Frame:** Solid ash structure  
**Seat & Back:** Upholstered seat and back  
**Finish:** Available in multiple stain colours  
\*Available in Counter Height

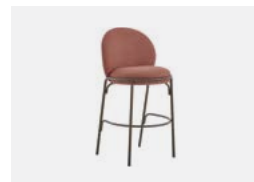
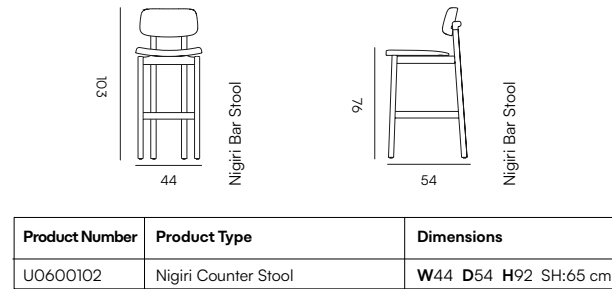

### Oyster Bar Stool

Product number: U0600080  
Designed by Enis Altinkaynak

**Frame:** Plywood back and powder coated metal or coloured stainless steel legs  
**Seat & Back:** Upholstered seat and back  
**Finish:** Available in steel or RAL colours  
\*Available in Counter Height

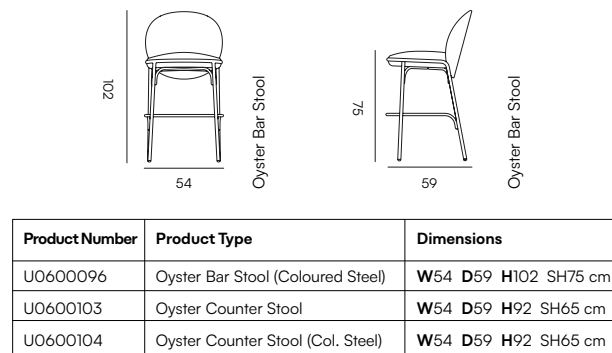

### Venus Bar Stool

Product number: U060036  
Designed by Burcu Ozdamar

**Frame:** Solid beech structure  
**Seat & Back:** Upholstered seat  
**Finish:** Available in multiple stain colours  
\*Available in Counter Height

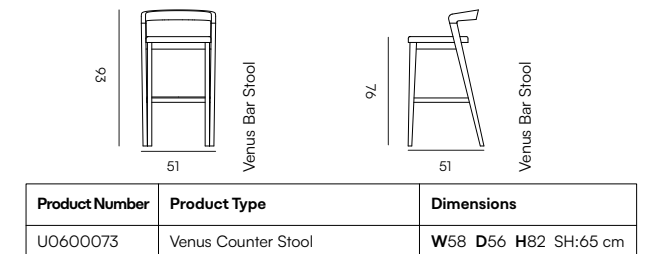

# Tables



## Palm V Round Table

Product number: U04000080  
Designed by Jean-Michel Wilmotte

**Top:** Oak veneer table top with metal edgewith metal edge  
**Leg:** Powder coated metal legs and top frame  
**Finish:** Available in multiple stain colours, legs available in RAL colours

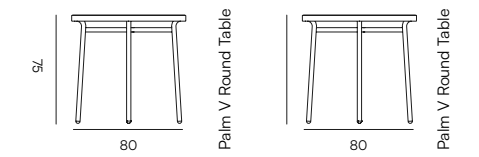

Product Number	Product Type	Dimensions
U04000083	Palm V Square Table	W80 D80 H75 cm

TABLES



## Roll B Table

Product number: U040030  
Designed by Parla Studio

**Top:** Oak veneer on birch plywood table top  
**Leg:** Powder coated metal leg and base  
**Finish:** Top and leg available in multiple stain colours, leg available in RAL colours

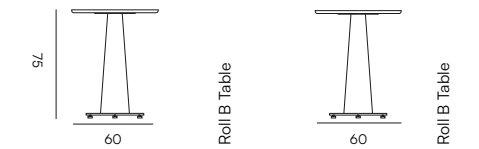

Product Number	Product Type	Dimensions
U04000026	Roll B Cocktail Table Q60	Dia60 H110 cm
U04000027	Roll B Table Q80	Dia80 H75 cm
U04000028	Roll B Table Q100	Dia100 H75 cm
U04000029	Roll B Table 60x60	W60 D60 H75 cm
U04000030	Roll B Cocktail Table 60x60	W60 D60 H110 cm
U04000031	Roll B Table 80x80	W80 D80 H75 cm
U04000032	Roll B Cocktail 60x60	W80 D60 H75 cm



## Tofu Table

Product number: U0400007  
Designed by Seda Yetkiner

**Top:** Marble top available in Alexander Black, Bruno Perla, Carrara, Emparador Mocca Marbles or Travertine Stone  
**Leg:** Natural oak veneer with coloured stainless steel trim base  
**Finish:** Available in multiple stain colours, steel base is available in steel colours

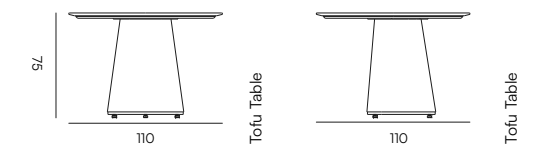

Product Number	Product Type	Dimensions
U04000038	Tofu Table Q100	Dia100 H75 cm
U04000039	Tofu Table Q90	Dia90 H75 cm
U04000040	Tofu Table Q80	Dia80 H75 cm
U0400021	Tofu Table Q65	Dia65 H65 cm



## Tofu G Table

Product number: U0400023  
Designed by Seda Yetkiner

- Top:** Clear glass top with coloured stainless steel joinery details, glass available in Extra Clear, Bronze and Smoked Glass options
- Leg:** Natural oak veneer with coloured stainless steel trim base
- Finish:** Leg available in multiple stain colours, coloured stainless steel trim available in coloured steel colors

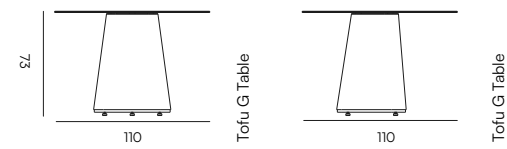

Product Number	Product Type	Dimensions
U04000073	Tofu G Table Q100	Dia100 H73 cm
U04000074	Tofu G Table Q90	Dia90 H73 cm
U04000075	Tofu G Table Q80	Dia80 H73 cm
U0400022	Tofu G Table Q65	Dia65 H63 cm



## Tofu V Table

Product number: U0400015  
Designed by Seda Yetkiner

- Top:** Oak veneer table top with solid wood edge
- Leg:** Oak veneer base with coloured stainless steel trim base
- Finish:** Top and leg available in multiple stain colours, coloured stainless steel trim available in coloured steel colors

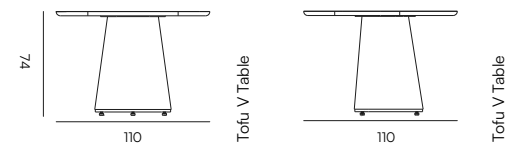

Product Number	Product Type	Dimensions
U04000035	Tofu V Table Q100	Dia100 H74 cm
U04000036	Tofu V Table Q90	Dia90 H74 cm
U04000037	Tofu V Table Q80	Dia80 H74 cm
U0400020	Tofu V Table Q65	Dia65 H64 cm



# Coffee Tables



## Blossom Coffee Table

Product number: U0900056  
Designed by Betül İnci

**Top:** Cast glass top  
**Leg:** Coloured stainless steel leg and terrazzo base  
**Finish:** Leg available in steel colours

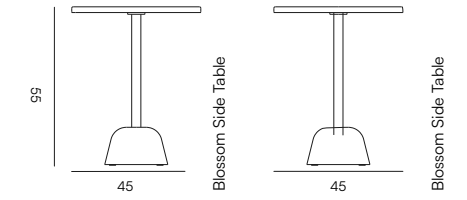

COFFEE TABLES



## Bone Coffee Table

Product number: U0900005  
Designed by Umut Karginoglu

**Top:** Marble top available in Alexander Black, Bruno Perla, Carrara, Emperador Mocca Marbles or Travertine Stone  
**Leg:** Solid beech legs  
**Finish:** Available in multiple stain colours

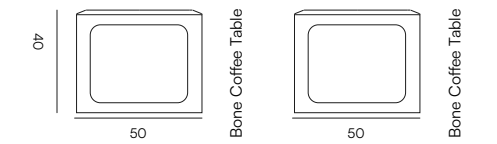

## Bone Mid Coffee Table

Product number: U0900073  
Designed by Umut Karginoglu

**Top:** Marble top available in Alexander Black, Bruno Perla, Carrara, Emperador Mocca Marbles or Travertine Stone  
**Leg:** Solid beech legs  
**Finish:** Available in multiple stain colours

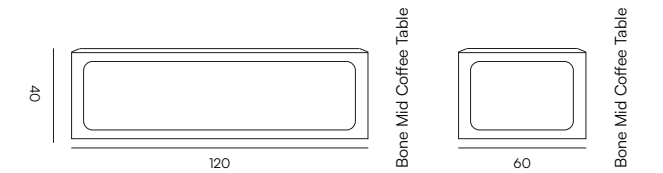

## Fleno Side Table

Product number: U0900064  
Designed by Berrak İlkan Sener & Yasemin Derici Ceri

**Top:** Upholstered genuine leather top  
**Leg:** Solid ash structure and with coloured stainless steel holder  
**Finish:** Available in steel colours, legs available in multiple stain colours, top available in Relax Series genuine leather colours

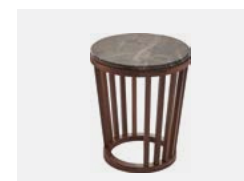
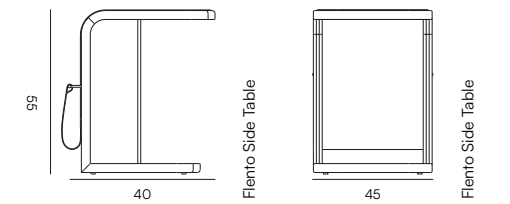

## Goba Coffee Table

Product number: U0900008  
Designed by Esin Sozer Kalender / Arketipo Design

**Top:** Marble top available in Alexander Black, Bruno Perla, Carrara, Emperador Mocca Marbles or Travertine Stone  
**Leg:** Solid beech legs  
**Finish:** Available in multiple stain colours

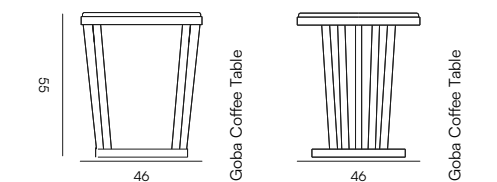

## Hug M Oval Coffee Table

Product number: U0900088  
Designed by Betül İnci

**Top:** Marble top available in Alexander Black, Bruno Perla, Carrara, Emperador Mocca marbles or Travertine Stone  
**Leg:** Oak veneered with solid wood edges  
**Finish:** Legs available in multiple stain colours

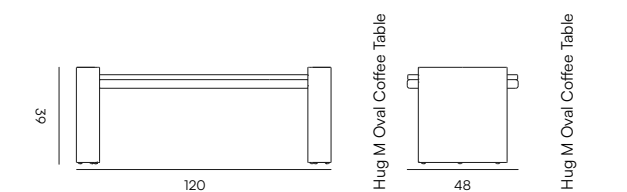





### Hug M Round Coffee Table

Product number: U0900085  
Designed by Betül İnci

**Top:** Marble top available in Alexander Black, Bruno Perla, Carrara, Emparador Mocca marbles or Travertine Stone  
**Leg:** Oak veneered with solid wood edges  
**Finish:** Legs available in multiple stain colours

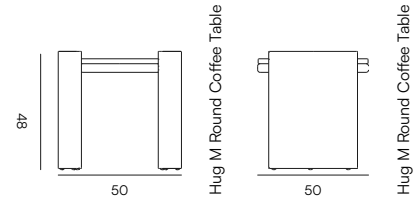

### Hug V Oval Coffee Table

Product number: U0900087  
Designed by Betül İnci

**Top:** Oak veneer table top  
**Leg:** Oak veneered with solid wood edges  
**Finish:** Legs available in multiple stain colours

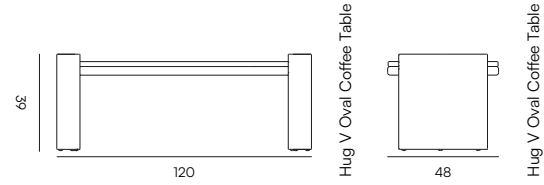

### Hug V Round Coffee Table

Product number: U0900084  
Designed by Betül İnci

**Top:** Oak veneer table top  
**Leg:** Oak veneered with solid wood edges  
**Finish:** Legs available in multiple stain colours

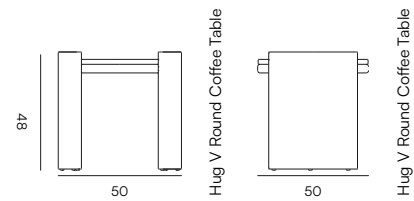

### London High Coffee Table (Coloured Steel)

Product number: U0900014  
Designed by Burcu Ozdamar

**Frame:** Oak veneer top  
**Leg:** Coloured stainless steel leg  
**Finish:** Available in multiple stain colours, legs available in steel or RAL colours

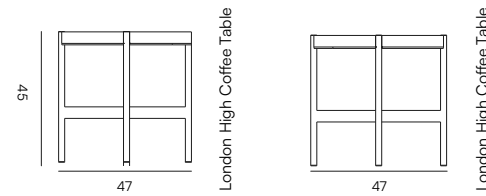

Product Number	Product Type	Dimensions
U0900071	London High Coffee Table	Dia47 H45 cm



### London Low Coffee Table (Coloured Steel)

Product number: U0900062  
Designed by Burcu Ozdamar

**Frame:** Oak veneer top  
**Leg:** Coloured stainless steel leg  
**Finish:** Available in multiple stain colours, legs available in steel or RAL colours

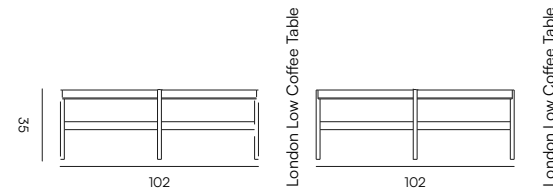

Product Number	Product Type	Dimensions
U0900070	London Low Coffee Table	Dia102 H35 cm



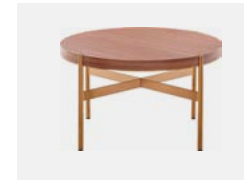

### London Mid Coffee Table

Product number: U0900060  
Designed by Burcu Ozdamar

**Frame:** Oak veneer top  
**Leg:** Coloured stainless steel leg  
**Finish:** Available in multiple stain colours, legs available in steel or RAL colours

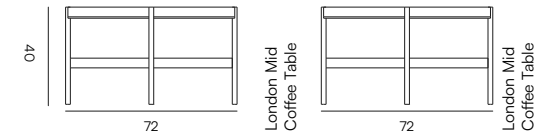

Product Number	Product Type	Dimensions
U0900072	London Mid Coffee Table	Dia72 H40 cm

COFFEE TABLES



### Mandala G Coffee Table

Product number: U090018  
Designed by Burcu Ozdamar

**Top:** Tempered glass top available in Extra Clear, Bronze and Smoked glass colours  
**Leg:** Powder coated metal leg  
**Finish:** Leg available in RAL colours

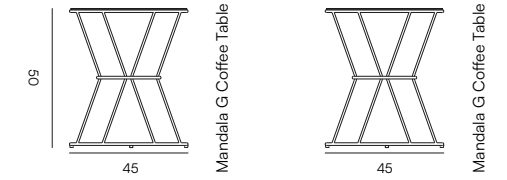

### Mandala M Coffee Table

Product number: U090019  
Designed by Burcu Ozdamar

**Top:** Marble top available in Alexander Black, Bruno Perla, Carrara, Emparador Mocca Marbles or Travertine Stone  
**Leg:** Powder coated metal leg  
**Finish:** Leg available in RAL colours

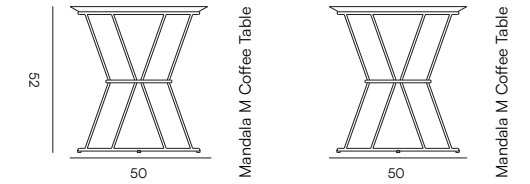

### Mandala V Coffee Table

Product number: U090019  
Designed by Burcu Ozdamar

**Top:** Wood veneer top available in natural walnut veneer or oak veneer with multiple stain colours  
**Leg:** Powder coated metal leg  
**Finish:** Leg available in RAL colours

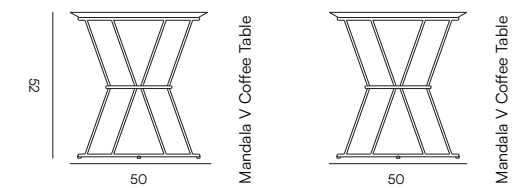

### Mawe Coffee Table

Product number: U0900054  
Designed by Yasemin Deric Ceri

**Top:** Glass top available in Extra Clear, Bronze and Smoked glass colours  
**Leg:** Solid ash legs  
**Finish:** Marble base available in Alexander Black marble or Travertine Stone

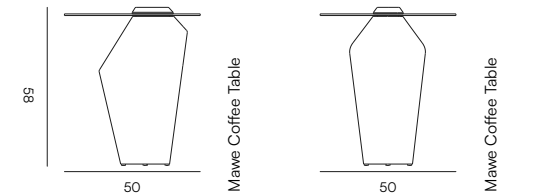

### Mawe Low Coffee Table

Product number: U0900067  
Designed by Yasemin Deric Ceri

**Top:** Glass top available in Extra Clear, Bronze and Smoked glass colours  
**Leg:** Solid ash legs  
**Finish:** Marble base available in Alexander Black marble or Travertine Stone

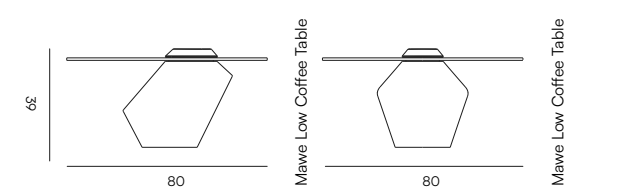



### Oyster Coffee Table

Product number: U0900063  
Designed by Enis Altinkaynak

- Top:** Marble top available in Alexander Black, Bruno Perla, Carrara, Emparador Mocca Marbles or Travertine Stone
- Leg:** Solid ash legs
- Finish:** Legs available in multiple stain colours

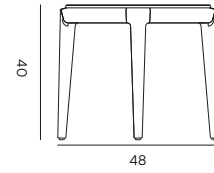

Oyster Coffee Table

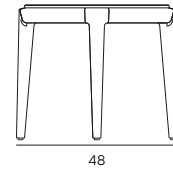

Oyster Coffee Table



### Palm V High Coffee Table

Product number: U09000095  
Designed by Jean-Michel Wilmotte

- Top:** Oak veneer table top with metal edge
- Frame:** Powder coated metal legs and top frame
- Finish:** Available in multiple stain colours, legs available in RAL colours

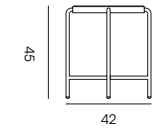

Palm V High Coffee Table

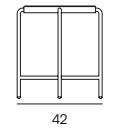

Palm V High Coffee Table



### Oyster M High Coffee Table

Product number: U0900090  
Designed by Enis Altinkaynak

- Top:** Marble top available in Alexander Black, Bruno Perla, Carrara, Emparador Mocca Marbles or Travertine Stone
- Leg:** Solid ash legs
- Finish:** Legs available in multiple stain colours

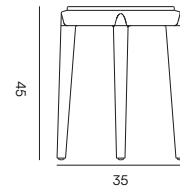

Oyster M High Coffee Table

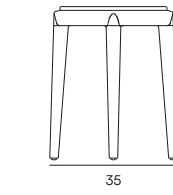

Oyster M High Coffee Table



### Palm V Low Coffee Table

Product number: U0900079  
Designed by Jean-Michel Wilmotte

- Top:** Oak veneer table top with metal edge
- Frame:** Powder coated metal legs and top frame
- Finish:** Available in multiple stain colours, legs available in RAL colours



Palm V Low Coffee Table



Palm V Low Coffee Table



### Oyster M Low Coffee Table

Product number: U0900092  
Designed by Enis Altinkaynak

- Top:** Marble top available in Alexander Black, Bruno Perla, Carrara, Emparador Mocca Marbles or Travertine Stone
- Leg:** Solid ash legs
- Finish:** Legs available in multiple stain colours

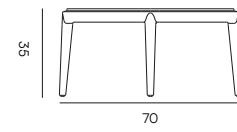

Oyster M Low Coffee Table

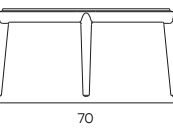

Oyster M Low Coffee Table



### Palm V Mid Coffee Table

Product number: U0900080  
Designed by Jean-Michel Wilmotte

- Top:** Oak veneer table top with metal edge
- Frame:** Powder coated metal legs and top frame
- Finish:** Available in multiple stain colours, legs available in RAL colours

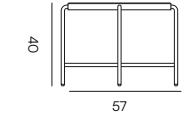

Palm V Mid Coffee Table

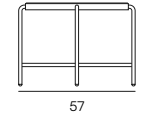

Palm V Mid Coffee Table



### Oyster V Coffee Table

Product number: U090039  
Designed by Enis Altinkaynak

- Top:** Oak veneer table top
- Leg:** Solid ash legs
- Finish:** Available in multiple stain colours

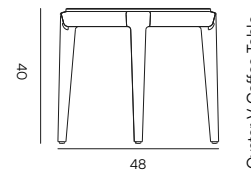

Oyster V Coffee Table

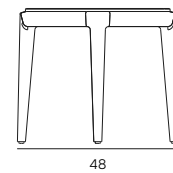

Oyster V Coffee Table



### Tofu Coffee Table

Product number: U0900053  
Designed by Seda Yetkiner

- Top:** Clear glass top with coloured stainless steel joinery details, glass available in Extra Clear, Bronze and Smoked Glass options
- Leg:** Natural oak veneer with coloured stainless steel trim base
- Finish:** Leg available in multiple stain colours, steel base trim and joinery detail available in steel colours

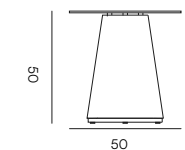

Tofu Coffee Table

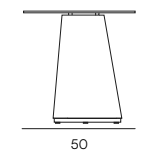

Tofu Coffee Table



### Oyster V High Coffee Table

Product number: U0900091  
Designed by Enis Altinkaynak

- Top:** Oak veneer table top
- Leg:** Solid ash legs
- Finish:** Available in multiple stain colours

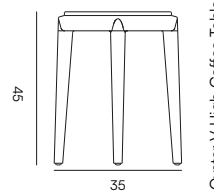

Oyster V High Coffee Table

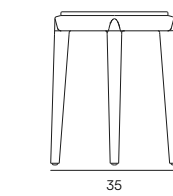

Oyster V High Coffee Table



### Tofu V Coffee Table

Product number: U0900066  
Designed by Seda Yetkiner

- Top:** Oak veneer on birch plywood table top
- Leg:** Oak veneer base with coloured stainless steel trim base
- Finish:** Available in multiple stain colours, steel base available in steel colours

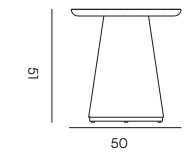

Tofu V Coffee Table

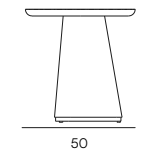

Tofu V Coffee Table



### Oyster V Low Coffee Table

Product number: U0900093  
Designed by Enis Altinkaynak

- Top:** Oak veneer table top
- Leg:** Solid ash legs
- Finish:** Available in multiple stain colours

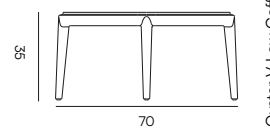

Oyster V Low Coffee Table

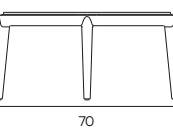

Oyster V Low Coffee Table

# Sofa



## Atlas Sofa

Product number: U030001  
Designed by Betül inci

**Frame:** Plywood and solid beech structure, solid beech legs  
**Seat & Back:** Upholstered seat and back  
**Finish:** Available in multiple stain colours

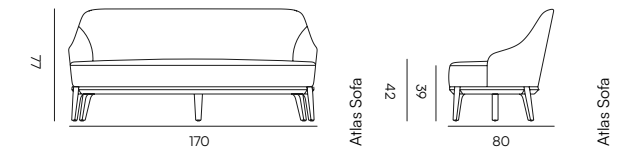

SOFAS



## Estival Sofa

Product number: U030012  
Designed by Parla Studio

**Frame:** Plywood and solid beech structure, powder coated metal base  
**Seat & Back:** Upholstered seat, back and cushions  
**Finish:** Available in RAL colours

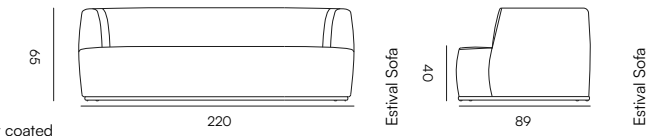

Product Number	Product Type	Dimensions
U030000079	Estival Sofa 180	W180 D89 H65 SH:40 cm



## Estival Left Sofa

Product number: U0300056  
Designed by Parla Studio

**Frame:** Plywood and solid beech structure, powder coated metal base  
**Seat & Back:** Upholstered seat, back and cushions  
**Finish:** Available in RAL colours

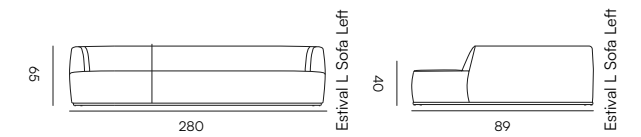

Product Number	Product Type	Dimensions
U0300055	Estival L Sofa Right	W280+200 D89 H65 SH:40 cm



## Goba Sofa

Product number: U030014  
Designed by Esin Sozer Kalender / Arketipo Design

**Frame:** Solid beech structure  
**Seat & Back:** Upholstered seat and back cushions  
**Finish:** Available in multiple stain colours

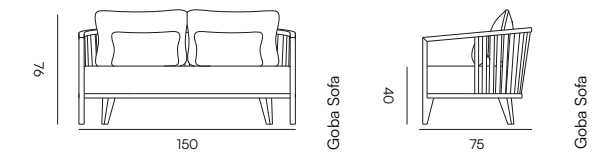

## Hew Sofa

Product number: U030000069  
Designed by Goodrich

**Frame:** Plywood structure and solid ash legs  
**Seat & Back:** Upholstered seat and back  
**Finish:** Available in multiple stain colours

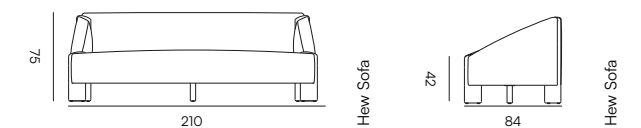

Product Number	Product Type	Dimensions
U030000082	Hew Sofa 180	W180 D84 H75 SH:42 cm



## Hug Sofa

Product number: U0300053  
Designed by Betül İnci

**Frame:** Plywood and solid beech structure, oak veneered base with solid wood edge  
**Seat & Back:** Upholstered seat  
**Finish:** Available in multiple stain colours

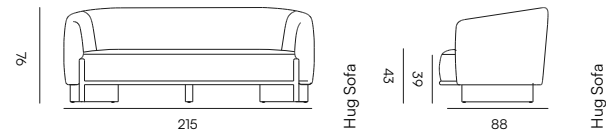

Product Number	Product Type	Dimensions
U030000081	Hug Sofa 180	W180 D88 H76 SH:43 cm



## Loop Sofa

Product number: U03000070  
Designed by Goodrich

**Frame:** Plywood structure  
**Seat & Back:** Upholstered seat and back

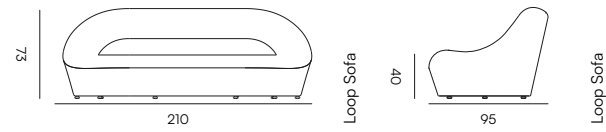

Product Number	Product Type	Dimensions
U030000070	Loop Sofa 180	W180 D95 H73 SH:40 cm



## Petra Sofa

Product number: U030032  
Designed by Betül İnci

**Frame:** Plywood and solid beech structure, powder coated metal legs  
**Seat & Back:** Upholstered seat and back  
**Finish:** Available in RAL colours

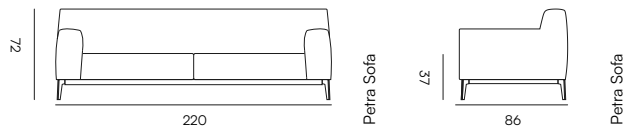

Product Number	Product Type	Dimensions
U030000078	Petra Sofa 180	W180 D86 H72 SH:37 cm



## Petra Left Sofa

Product number: U0300057  
Designed by Betül İnci

**Frame:** Plywood and solid beech structure, powder coated metal legs  
**Seat & Back:** Upholstered seat and back  
**Finish:** Available in RAL colours

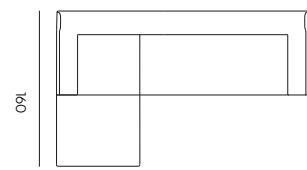
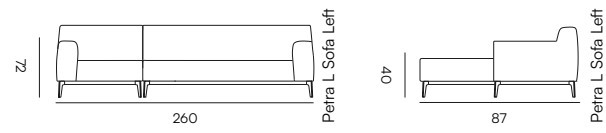

Product Number	Product Type	Dimensions
U0300058	Petra L Sofa Right	W260+160 D87 H72 SH:40 cm



# Outdoor



## Iona Chair

Product number: U0100285  
Designed by Deniz Albayrak

**Frame:** Powder coated metal structure with outdoor treatment, back structure woven with polyester rope available in black, tan and khaki rope colours  
**Seat & Back:** Solid iroko base and PVC seat with upholstered seat cushion  
**Finish:** Available in RAL colours with outdoor treatment, base available in natural iroko colour

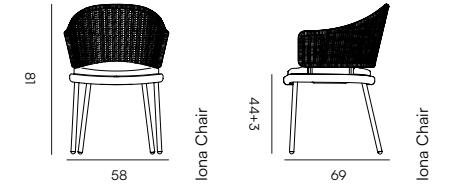

## Palm A Chair

Product number: U0100315  
Designed by Jean-Michel Wilmotte

**Frame:** Powder coated metal structure with armrest with outdoor treatment  
**Seat & Back:** Removable upholstered seat cushion

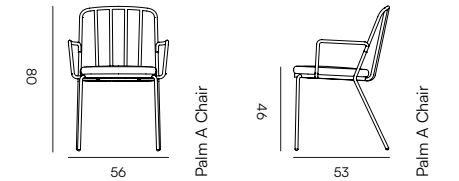

## Palm Chair

Product number: U0100258  
Designed by Jean-Michel Wilmotte

**Frame:** Powder coated metal structure with outdoor treatment  
**Seat & Back:** Removable upholstered seat cushion

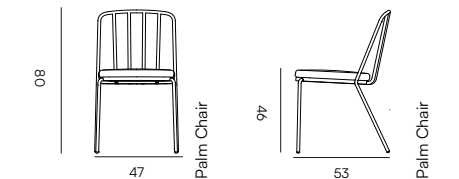

## Bloom E Club Armchair

Product number: U0200102  
Designed by Betül İnci

**Frame:** Solid iroko legs and metal structure woven with polyester rope available in black, tan and khaki rope colours  
**Seat & Back:** Upholstered seat and back cushions  
**Finish:** Available in natural iroko colour

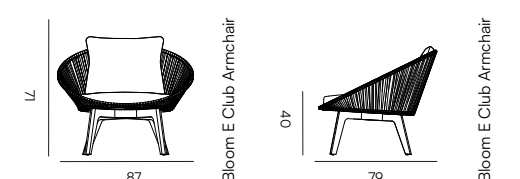

## Goba T Armchair

Product number: U020034  
Designed by Esin Sozer Kalender / Arketipo Design

**Frame:** Solid iroko structure  
**Seat & Back:** Upholstered seat and back cushions  
**Finish:** Available in natural iroko colour

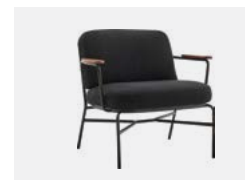
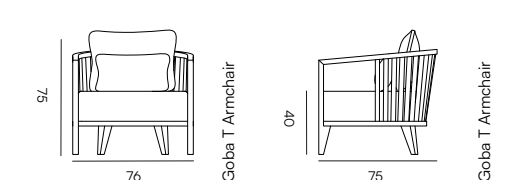

## Palm Armchair

Product number: U0200138  
Designed by Jean-Michel Wilmotte

**Frame:** Powder coated metal structure with outdoor treatment  
**Seat & Back:** Removable upholstered seat & back cushion  
**Armrests:** Solid wood

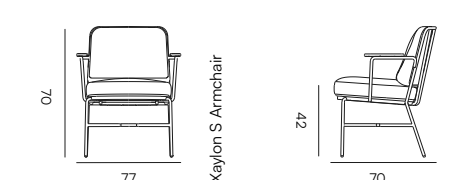



### Palm Comfort A Armchair

Product number: U020066  
Designed by Jean-Michel Wilmotte

**Frame:** Powder coated metal structure with outdoor treatment  
**Seat & Back:** Removable upholstered seat & back cushion  
**Armrests:** Solid wood

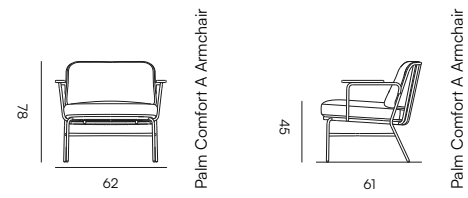

### Palm Comfort Armchair

Product number: U0200140  
Designed by Jean-Michel Wilmotte

**Frame:** Powder coated metal structure with outdoor treatment  
**Seat & Back:** Removable upholstered seat & back cushion

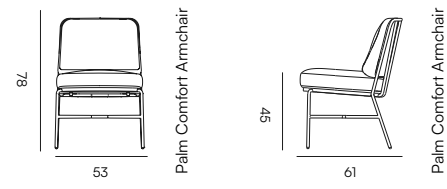

### Palm Pouf

Product number: U0700023  
Designed by Jean-Michel Wilmotte

**Frame:** Powder coated metal structure with outdoor treatment  
**Seat:** Removable upholstered seat cushion

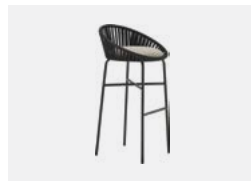
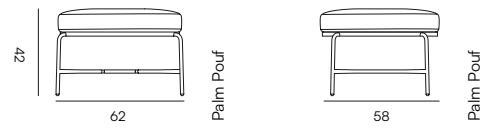

### Bloom E Bar Stool

Product number: U060005  
Designed by Betül İnci

**Frame:** Powder coated metal structure with outdoor treatment, back structure woven with PE rope  
**Seat & Back:** Upholstered seat cushion  
**Finish:** Frame available in RAL colours, rope is available in Grey white, Antracite Grey, Lemon Verbena and Vermillion Red

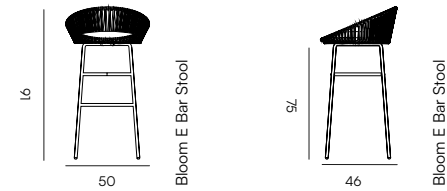

Product Number	Product Type	Dimensions
U0600106	Bloom E Counter Stool	W50 D46 H81 SH:65 cm



### Palm Bar Stool

Product number: U0600089  
Designed by Jean-Michel Wilmotte

**Frame:** Powder coated metal structure with outdoor treatment  
**Seat & Back:** Removable upholstered seat cushion  
\*Available in Counter Height

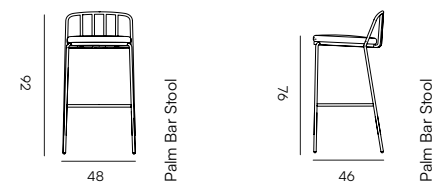

Product Number	Product Type	Dimensions
U0600087	Palm Counter Stool	W47 D46 H82 SH:66 cm



### Palm Compact Comfort A Bar Stool

Product number: U0600095  
Designed by Jean-Michel Wilmotte

**Frame:** Powder coated metal structure with outdoor treatment  
**Seat & Back:** Removable upholstered seat & back cushion  
**Armrests:** Solid wood  
\*Available in Counter Height

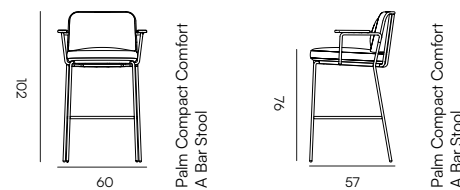

Product Number	Product Type	Dimensions
U0600094	Palm Compact Comfort A Counter Stool	W60 D57 H92 SH:66 cm

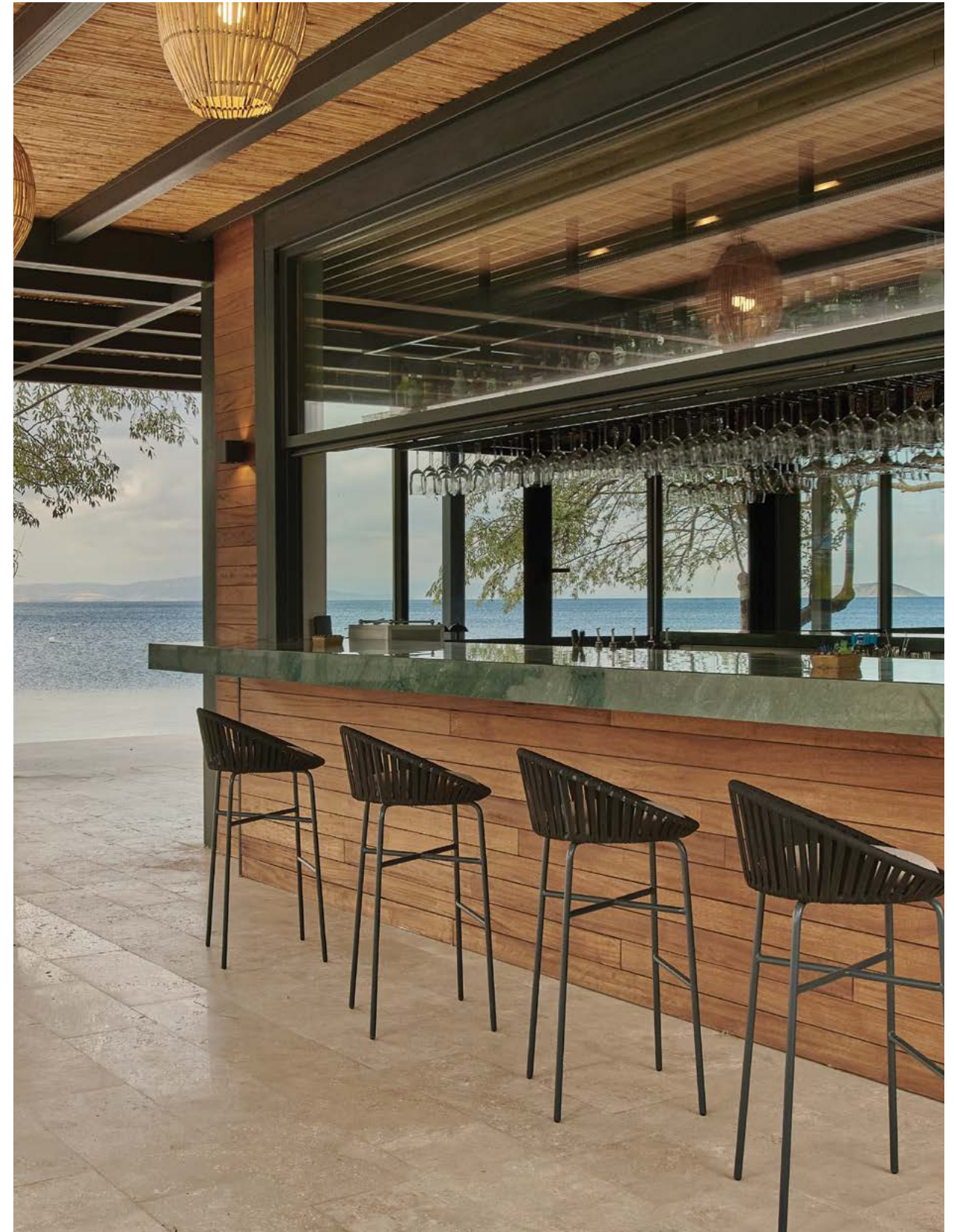

Pınar Hotel - Balıkesir, Türkiye

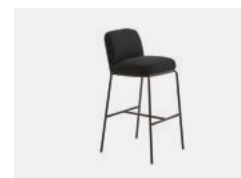

### Palm Compact Comfort Bar Stool

Product number: U0600085  
Designed by Jean-Michel Wilmotte

**Frame:** Powder coated metal structure with outdoor treatment  
**Seat & Back:** Removable upholstered seat & back cushion  
\*Available in Counter Height

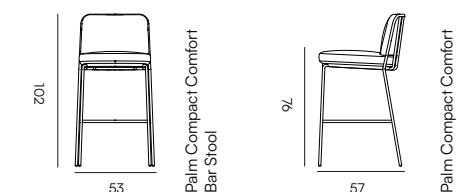

Product Number	Product Type	Dimensions
U0600084	Palm Compact Comfort Counter Stool	W53 D57 H102 SH:76 cm

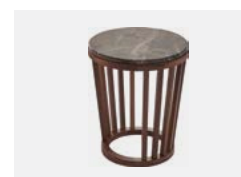

### Goba T Coffee Table

Product number: U090036  
Designed by Esin Sozer Kalender / Arketipo Design

**Top:** Marble top available in Alexander Black, Bruno Perla, Carrara, Emparador Mocca Marbles or Travertine Stone  
**Leg:** Solid iroko  
**Finish:** Available in natural iroko colour

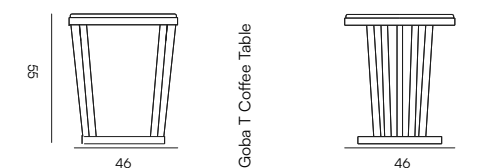

### Palm C High Coffee Table

Product number: U090000096  
Designed by Jean-Michel Wilmotte

**Top:** Compact laminate Top  
**Frame:** Powder coated metal structure with outdoor treatment

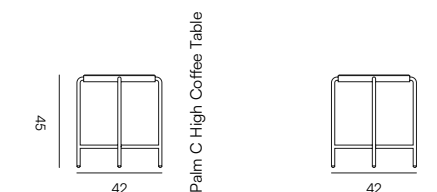

### Palm C Low Coffee Table

Product number: U090000100  
Designed by Jean-Michel Wilmotte

**Top:** Compact laminate Top  
**Frame:** Powder coated metal structure with outdoor treatment

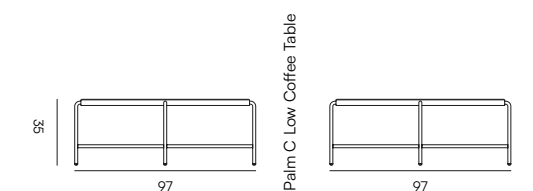

### Palm C Mid Coffee Table

Product number: U090000098  
Designed by Jean-Michel Wilmotte

**Top:** Compact laminate Top  
**Frame:** Powder coated metal structure with outdoor treatment

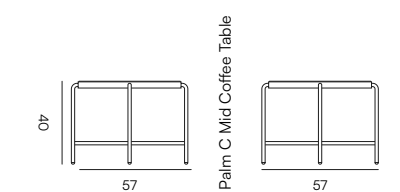

### Palm M High Coffee Table

Product number: U0900083  
Designed by Jean-Michel Wilmotte

**Top:** Compact laminate Top  
**Frame:** Powder coated metal structure with outdoor treatment

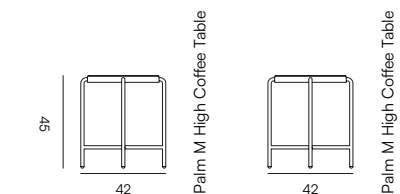





### Palm M Low Coffee Table

Product number: U090000099  
Designed by Jean-Michel Wilmotte

**Top:** Marble top  
**Frame:** Powder coated metal structure with outdoor treatment

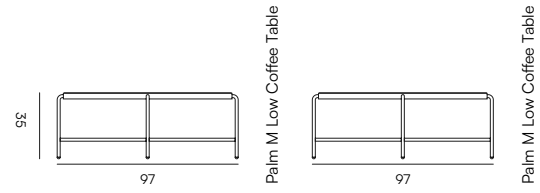

### Palm M Mid Coffee Table

Product number: U090000097  
Designed by Jean-Michel Wilmotte

**Top:** Marble top  
**Frame:** Powder coated metal structure with outdoor treatment

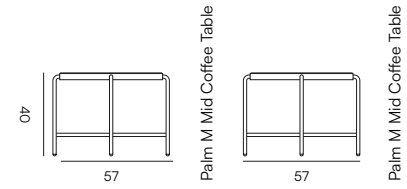

### Goba T Sofa

Product number: U030050  
Designed by Esin Sozer Kalender / Arketipo Design

**Frame:** Solid iroko structure  
**Seat & Back:** Upholstered seat and back cushion  
**Finish:** Available in natural iroko colour

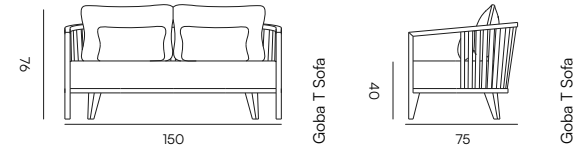

### Palm A Bench Outdoor

Product number: U1100014  
Designed by Jean-Michel Wilmotte

**Frame:** Powder coated metal structure with outdoor treatment  
**Seat & Back:** Removable upholstered seat cushion

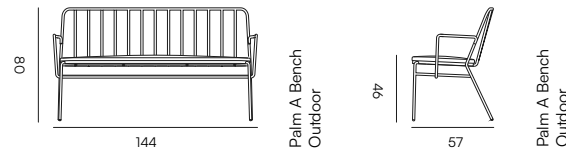

### Palm Sofa

Product number: U0300054  
Designed by Jean-Michel Wilmotte

**Frame:** Powder coated metal structure with outdoor treatment  
**Seat & Back:** Removable upholstered seat & back cushion with leather backwrap detail  
**Armrests:** Solid wood

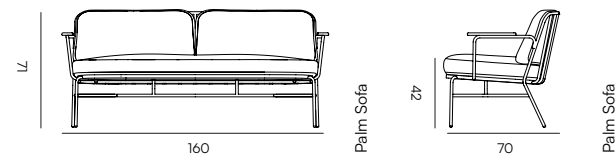

### Palm Daybed Left

Product number: U030000071  
Designed by Jean-Michel Wilmotte

**Frame:** Powder coated metal structure with outdoor treatment  
**Seat & Back:** Removable upholstered seat & back cushion

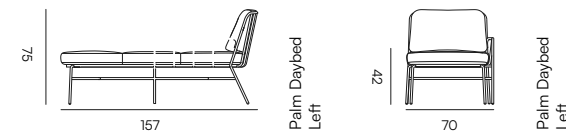

Product Number	Product Type	Dimensions
U0300061	Palm Daybed Right	W157 D70 H75 SH:42 cm



# Storage & Consoles



## Fleto Console

Product number: U1100012  
Designed by Berrak Ilkcan Sener & Yasemin Derici Ceri

**Top:** Upholstered genuine leather top  
**Frame:** Solid ash and coloured stainless steel legs  
**Finish:** Available in multiple stain colours legs available in multiple stain colours. Top available in Bitter and Cinnamon

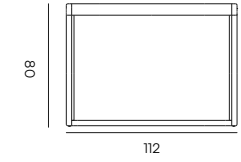

Fleto Console

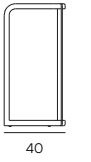

Fleto Console



## Rain Small Console

Product number: U1100016  
Designed by Buket Hoscan Bazman

**Body:** Oak veneer cabinet with glass doors and metal handle & legs  
**Finish:** Available in multiple stain colours, legs available in coloured steel colours

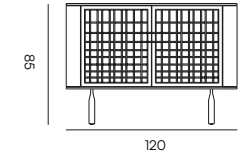

Rain Small Console

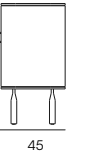

Rain Small Console



## Rain Console

Product number: U1100017  
Designed by Buket Hoscan Bazman

**Body:** Oak veneer cabinet with glass doors and metal handle & legs  
**Finish:** Available in multiple stain colours, legs available in coloured steel colours

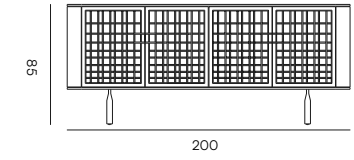

Rain Console

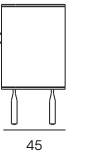

Rain Console



# Materials & Colors

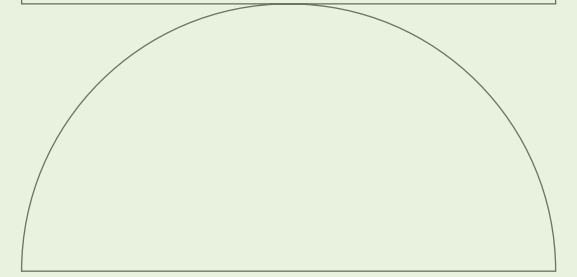
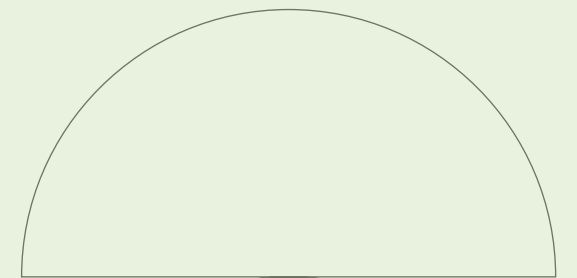
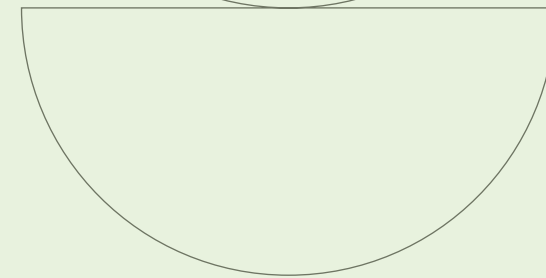

# Solid Wood

**Ash**

Sunrise Smoked Oak Light Walnut Brown Dark Walnut Mocha Bitter Brown Wenge Black

**Beech**

Sunrise Smoked Oak Light Walnut Brown Dark Walnut Mocha Bitter Brown Wenge Black

# Wood Veneer

**Oak**

Sunrise Smoked Oak Light Walnut Brown Dark Walnut Mocha Bitter Brown Wenge Black

**American Walnut**

Natural

\*\* The price will change in accordance with American Walnut Veneer choice.

\*We use quarter cut veneer sheets with slip matching on plywood as our standard for wood veneer options.

# Metal

**Brass**

Antique Brass

**Powder Coated Matt**

Oyster White Matt 1013 Grey White Matt 9002 Stone Grey Matt 7030 Quartz Grey Matt 7039 Truffe Matt 564 Copper Matt 835 Gold Matt 12 Chocolate Matt 20 Black Grey Matt 7021 Jet Black Matt 9005

\*Parla recommends Powder Coated metal in **matt finish for indoor use** and aluminium or treated metal in **textured finish for outdoor use**.

**Coloured Steel**

03 Ivory Polished 04 Ivory Brushed 05 Saffron Polished 06 Saffron Brushed 09 Coral Polished\* 10 Coral Brushed\*

\* This finish requires an additional 2 weeks for production.

# Glass and Stone

Alexander Black Marble Bruno Perla Marble Carrara Marble Emparador Mocca Marble Travertine Stone Clear Glass Bronze Tinted Glass Smoked Tinted Glass Black Painted Glass

# Outdoor

## Iroko



Natural\*

\* Direct exposure to sunlight will eventually affect Iroko's colour, creating a darker shade in time.

## Powder Coated Textured

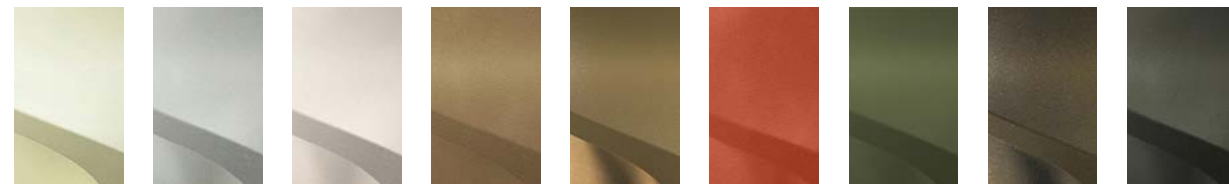

Oyster White Textured 1013   Grey White Textured 9002   Pure White Textured 9010   Grey Beige Textured 1019   Peanut Textured 967   Salmon Orange Textured 2012   Reed Green Textured 6013   Earth Textured 39   Stone Grey Textured 7030

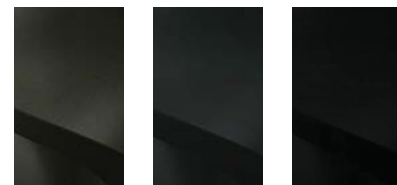

Umbra Grey Textured 7022   Black Grey Textured 7021   Jet Black Textured 9005

## Rope



Flat Rope Tan   Flat Rope Khaki   Flat Rope Black   Woven Rope Tan   Woven Rope Khaki   Woven Rope Black   Grey White GR10   Lemon Verbena K10   Vermillion TR17   Anthracite Grey GR23

# Upholstery / Fabric

## Category A Athena



1131   1144   1152   1158   1192   1203   1209   1212   1215



1225   1230   1238

\*\* Price will change according to the FR and CRIB 5 application. Production time will be extended.



Material	%60 Polyester %40 Cotton	Fastness to rubbing	Wet:5, Dry:5 (ISO 105 - X12)
Width	Approximately 55 inches (140 cm (±2%))	Flammability	FR and CRIB 5 treatment applicable upon request with extra cost.**
Weight	ISO 2286-2 440 ± 20 gr	Sustainability	Certified to OEKO-TEX®
Durability	>40.000 ISO 12947-1		
Light fastness	4/5 according to ISO 105-B02		

## Category A Velluto



K18010   K180J3   K1848   K180T8   K180BM   K1821   K180R7   K180N9   K180K7   K180E2

\*\* Price will change according to the FR and CRIB 5 application. Production time will be extended.



Material	%59 TEXTURED PES %41 PES	Flammability	NF P 92 5XX M1-M2-M3
Width	140 cm +/- %2		DIN 4102 B1-B2
Weight	425 gr / mt <sup>2</sup>		ECER 11803
Durability	100.000 > Martindale		CRIB 5**
Light fastness	EN ISO 105-B02(Grade 6/8)	Additional Tests	Antibacterial ASTM E 2149-13, Antiviral ISO 18184 Sprey Test EN ISO 4920, AATCC193 , AATC 118
Fastness to rubbing	Wet: 4, Dry: 3/4 (ISO 105 - X12)	Airflow	ISO 9237
Flammability	BS 5852 Source 0 BS 5852 Source 1 EN 1021-1, EN 1021-2 EN 1021-2 FR TREATED IMO PART 8, IMO PART 8 FR TESTED BS 7176 LOW HAZARD BS 7176 MEDIUM HAZARAD NFPA 260 PASS, CAL TB 117 - PASS	Sustainability	EU Eco Label

## Category B

Reye

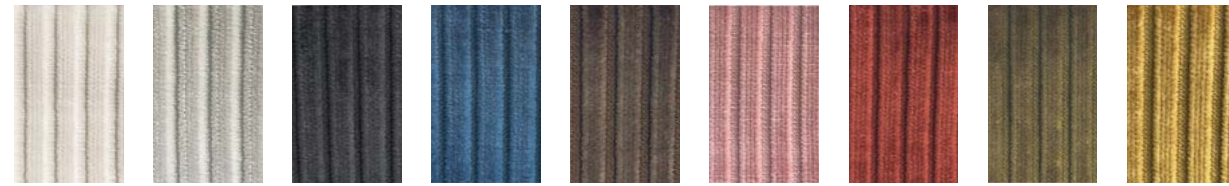

6247 6250 6253 6255 6259 6262 6264 6279 6281

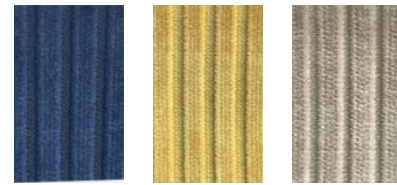

6283 6284 6287

\*\* Price will change according to the FR and CRIB 5 application. Production time will be extended.

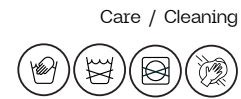

Material	%100 PES	Flammability	EN 1021-1
Width	142 cm +/- %2		EN 1021-2
Weight	430 gr / m <sup>2</sup>		CALL 117
Durability	120.000 > Martindale		NFPA 260
Light fastness	EN ISO 105-B02(Grade 6/8)	Additional Tests	AATCC193 , AATC 118
Fastness to rubbing	Wet: 4, Dry: 3/4 (ISO 105 - X12)	Sustainability	Recycled 100 Claim Standard, RCS
Flammability	EN ISO 13936-2		Blended - Recycled Claim Standard,
	BS 5852 PART 1 SOURCE 0		Certified to OEKO-TEX® Standard 100
	BS 5852 PART 1 SOURCE 1		
	BS 5852 Part1 Source 1 Fr Treated		
	BS 5852 CRIB-5**		

## Category B

Teddy

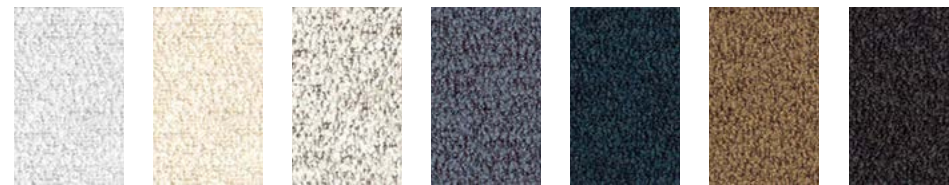

000 004 016 027 037 058 076

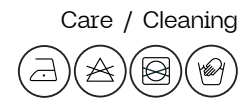

Material	% 59 Acrylic - % 41 Pes	Flammability	BS 5852 Source 0
Width	140 cm +/- %2		EN 1021-1
Weight	785 gr m <sup>2</sup> +/- %5		NFPA 260
Durability	40.000 > Martindale		CAL TB 117 - PASS
			CRIB 5
		Sustainability	Certified to OEKO-TE

## Category C

Luxe



837 823 408 437 231 203 105

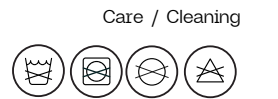

Material	100% Polyester with Microporous Film and FR Laminate	LRV	8.6 (0-10)
Width	140 cm +/- %2	Waterproof	Hydrostatic head >5m
Weight	452 gr / m <sup>2</sup>	Flammability	BS 5852 IGN Source 5
Durability	70.000 > Martindale		BS 7176 Medium Hazard
	50.000 > Wyzenbeek DR		BS EN 1021 1/2
Light fastness	EN ISO 105-B02 (Grade 4-5+)		CAL TB 117
Fastness to rubbing	Wet: 4, Dry: 4 (ISO 105 - X12)		IMO FTP CODE 2010 Part 8
			NFPA 260

## Category C

Alba

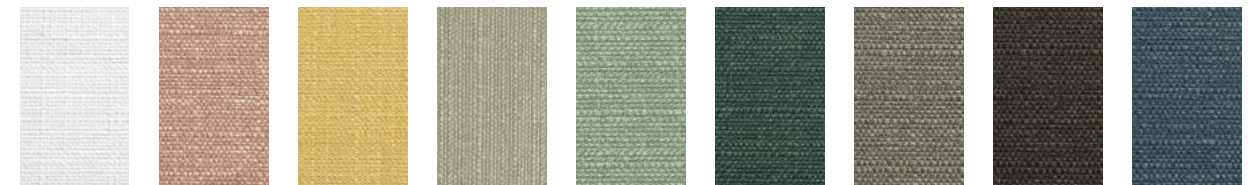

829 618 326 952 251 203 904 902 108

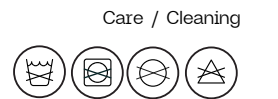

Material	100% Polyester with Microporous Film and FR Laminate	Hydrostatic Head	5.7 (0-10)
Width	138 cm +/- %2	Flammability	6M
Weight	430 gr / m <sup>2</sup>		BS 5852 IGN Source 5
Durability	130.000 > Martindale		BS 7176 Medium Hazard
	65.000 > Wyzenbeek DR		BS EN 1021 1/2
Light fastness	EN ISO 105-B02 (Grade 5+)		CAL TB 117
Fastness to rubbing	Wet: 4, Dry: 4 (ISO 105 - X12)		IMO FTP CODE 2010 Part 8
			NFPA 260

\* Not suitable for piping.

Category C  
Riva

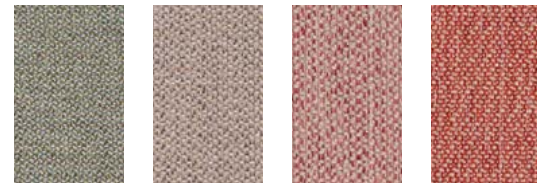

271 837 618 637



Care / Cleaning

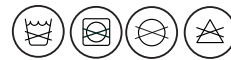

Material	100% Polyester with Microporous Film and FR Laminate
Width	140 cm +/- %2
Weight	400 gr / mt <sup>2</sup>
Durability	60.000 > Martindale 50.000 > Wyzenbeek DR
Light fastness	EN ISO 105-B02 (Grade 6+)
Fastness to rubbing	Wet: 4, Dry: 4 (ISO 105 - X12)
Hydrostatic Head	13.7

Flammability	3M+ BS 5852 IGN Source 5 BS 7176 Medium Hazard BS EN 1021 1/2 CAL TB 117 IMO FTP CODE 2010 Part 8 NFPA 260
--------------	--

Category C  
Main Line Flax



MLF14 MLF16 MLF17 MLF20 MLF26 MLF32 MLF35 MLF37

\*\* Price will change according to the CRIB 5 application. Production time will be extended.

Care / Cleaning



Material	70% Virgin Wool, 30% Flax
Width	Approximately 55 inches (140 cm)
Weight	Approximately 437 g/m <sup>2</sup> (612 g/lin.m ±5%)
Durability	≥50,000 Martindale cycles
Light fastness	5 (ISO 105 - B02)
Fastness to rubbing	Wet: 3, Dry: 4 (ISO 105 - X12)

Flammability	BS 5852 ignition source 5 (CRIB 5) EN 1021-1&2 cigarette & match BS 7176 low hazard BS 7176 medium hazard NF D 60-013 ÖNORM B 3825 & A 3800-1 (58kg/m <sup>3</sup> CMHR Foam) UNI 9175 Classe 1 IM BS 5867-2: Type B curtains & drapes CRIB 5**
Sustainability	Certified to the EU Ecolabel Certified to Indoor Advantage™ "Gold" Rapidly renewable and compostable Made from wool and bast fibre

Category C  
Bolt

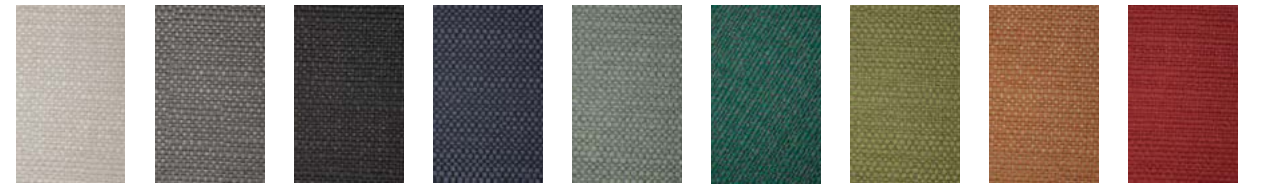

16 Silver 20 Aluminium 22 Jet 23 Ink 27 Turquoise 30 Emerald 32 Leaf 37 Canyon 38 Chili

\*\* Price will change according to the CRIB 5 application. Production time will be extended.

Care / Cleaning



Material	Jacquard Weave, 60% Polyester, 40% Polypropylene, 100% filament
Width	Usable width 142.00 cm
Weight	Approximately 342 g/m <sup>3</sup>
Repeat	Plain
Durability	100.000 Martindale
Pilling	Grade 4
Light Fastness	Grade 4
Fastness to Water	Grade 5
Fastness to Wear	Grade 4
Tensile Strength	Tensile strength weft in N/5cm 1200 Tensile strength warp in N/5cm 1400

Tearing Strength	Tensile strength warp in N/5cm 1400
Elongation	WARP 150 D WEFT 150 N
Fastness to Rubbing	WARP 29,5% WEFT 30,5% 4-5 dry or wet
Flammability	FMVSS 302 Pass, BS5852 source 1 comment BS5852 source 0, CAL 117 Complies NFPA 260, CRIB 5**
Colouring Type	Yarn dyed
Wyzenbeek	(double rubs): 48.000
Treatment	Mildew Resistant, Stain-Free Technology, Anti bacterial - microbial, Odour Resistant
Sustainability	OEKO-TEX, ISO 14001

Category D  
Remix 3



123 163 373 422 653 662 452 692 873



933 982

\*\* Price will change according to the CRIB 5 application. Production time will be extended.

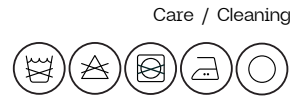

Material	90% New wool (worsted), 10% Nylon	Flammability	BS 5852 Crib 5 with treatment **
Width	Approximately 55 inches (140 cm)		AS/NZS 1530.3, AS/NZS 3837 class 2
Weight	Approximately 420 g/lin.m		BS 5852 ignition source 3, BS 5852 part 1
Durability	≥100,000 Martindale cycles (EN ISO 12947)		EN 1021-1/2
Pilling	4 (EN ISO 12945)		GB 50222 B1 with treatment
Light fastness	5-7 (ISO 105 - B02)		IMO FTP Code 2010:Part 7 with treatment
Fastness to rubbing	Wet: 4-5, Dry: 4-5 (ISO 105 - X12)		IMO FTP Code 2010:Part 8
			NF D 60 013, NFPA 260
			SN 198 898 5.3 with treatment, UNI 9175 1IM
			US Cal. Bull. 117-2013, ÖNORM B1/Q1, CRIB 5**
		Sustainability	Complies with EU ecolabel "The Flower"
		Absorption	0.55/Class D (flat), 0.80/Class B (waved) EN ISO 354
		Airflow	465 Pa s/m EN 29053

Category E  
Steelcut Trio

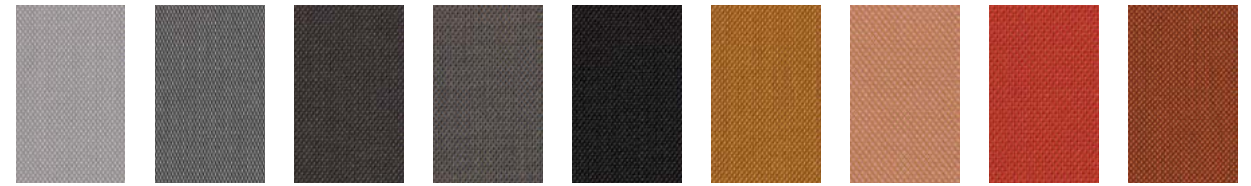

105 133 176 253 383 453 506 533 576



756 996

\* To pass this test flame retardant treatment is necessary. We are looking into more environmental friendly alternatives but for now the external finisher may use a treatment containing halogen based flame retardants.

\*\* Price will change according to the CRIB 5 application. Production time will be extended.

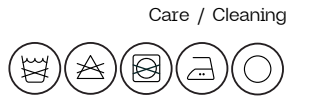

Material	90% New wool (worsted), 10% Nylon	Flammability	BS 5852 ignition source 3, BS 5852 part 1
Width	Approximately 55 inches (140 cm)		EN 1021-1/2
Weight	Approximately 770 g/lin.m		GB 50222 B1 with treatment
Durability	≥100,000 Martindale cycles EN ISO 12947		IMO FTP Code 2010:Part 8
Pilling	4 (EN ISO 12945)		NF D 60 013, NFPA 260
Light fastness	5 (ISO 105 - B02)		SN 198 898 5.3 with treatment , UNI 9175 1IM
Fastness to rubbing	Wet: 4-5, Dry: 4-5 (ISO 105 - X12)		US Cal. Bull. 117-2013, ÖNORM B1/Q1
			Complies with EU ecolabel "The Flower"
Flammability	BS 5852 Crib 5 with treatment**	Sustainability	0.70/Class C (flat), 0.95/Class A (waved)
	AS/NZS 1530.3, AS/NZS 3837 class 2	Absorption	EN ISO 354
		Airflow	910 Pa s/m EN 29053

Category E  
Hallingdal 65

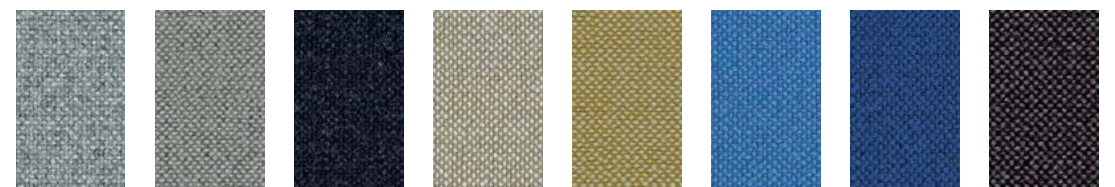

116 130 180 220 407 733 754 368

\* To pass this test flame retardant treatment is necessary. We are looking into more environmental friendly alternatives but for now the external finisher may use a treatment containing halogen based flame retardants.

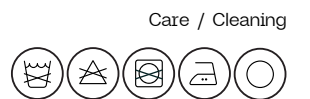

Material	70% New wool, 30% Viscose	Flammability	BS 5852 Part 1
Width	Approximately 51 inches (130 cm)		EN 1021-1/2
Weight	Approximately 795 g/lin.m		GB 50222 B1 with treatment *
Durability	≥100,000 Martindale cycles EN ISO 12947		IMO FTP Code 2010:Part 8
Pilling	3-4 (EN ISO 12945)		NF D 60 013
Light fastness	5-7 (ISO 105 - B02)		NFPA 260, CRIB 5
Fastness to rubbing	Wet: 3-5, Dry: 4-5 (ISO 105 - X12)		SN 198 898 5.3 with treatment *, UNI 9175 1IM
Flammability	BS 5852 CRIB 5	Sustainability	US Cal. Bull. 117-2013, ÖNORM B1/Q1
	AS/NZS 1530.3	Absorption	Complies with EU ecolabel "The Flower"
	AS/NZS 3837 class 2	Airflow	0.45/Class D (flat), 0.70/Class C (waved) EN ISO 354
	BS 5852 ignition source 3		182 Pa s/m EN 29053



# Upholstery / Artificial Leather

## Category F Coda 2

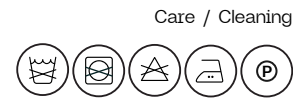

Material	%90 New wool %10 Nylon
Width	Approximately 55 inches (140 cm (±2%))
Weight	Approximately 860 g/lin.m, 27.7 oz/ly
Pilling	Note 4 EN ISO 12945
Light fastness	Note 5-7 ISO 105-B02
Fastness to rubbing	Dry note 4-5 ISO 105-X12 Wet note 4-5 ISO 105-X12

Abrasion	Approx. 100.000 Martindale rubs, EN ISO 12947
Flammability	US Cal. Bull. 117-2013 CRIB 5**
Sustainability	GREENGUARD GOLD, Certified to OEKO-TEX®

## Category F Fifty Fifty

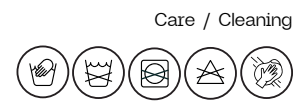
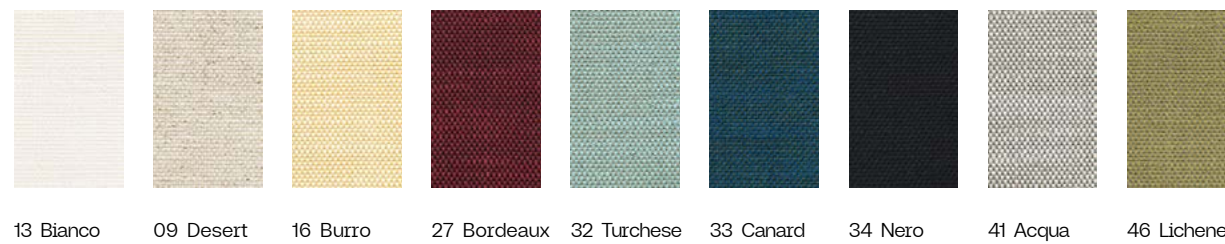

Material	%60 Polyester %40 Cotton
Width	Approximately 55 inches (140 cm (±2%))
Weight	ISO 2286-2 440 ± 20 gr
Durability	>40.000 ISO 12947-1

Light fastness	4/5 according to ISO 105-B02
Fastness to rubbing	Wet:5, Dry:5 (ISO 105 - X12)
Sustainability	Certified to OEKO-TEX®

## Category A Nona FR

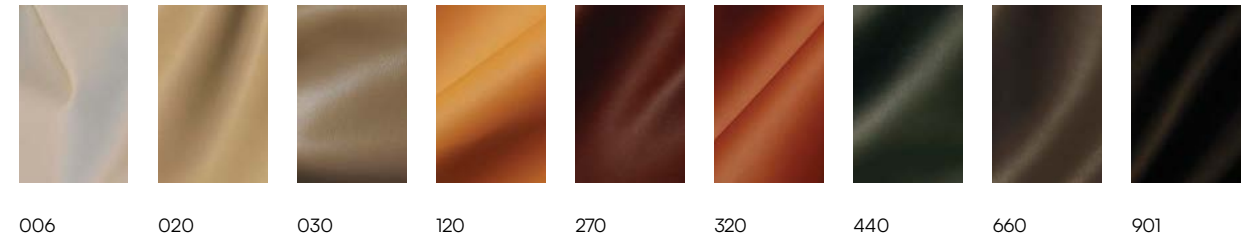

Material	78% Polyvinyl Chloride, 20 Polyester, 2% Vinyl Acrylic Laquer
Width	Approximately 55 inches (140 cm ±1 )
Weight	Approximately 650 g/lin.m ±5%
Thickness	1,15 ± %5
Tensile Strenght	WARP >245N WEFT >400N
Tear Strenght	WARP >30N WEFT >25N
Durability	>100.000 rubs DIN 53863
Adhesion	40N
Light fastness	5/5 (ISO 105 - B02)
Fastness to rubbing	Grade 6 wet or dry

Fastness to rubbing	Water Repellent BS 5852 Part 1 Cigarette & Match Test
Water Resistance	EN 1021-1 / 2 Cigarette & Match Test
Flammability	CAL 116, CAL 117 NFPA 260, DIN 4102 NFP 92 503 M3 IMO FTP Code Annex 1 Part 8
Sustainability	Certified to OEKO-TEX®

Category B  
Best FR

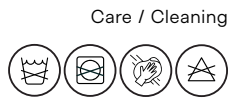
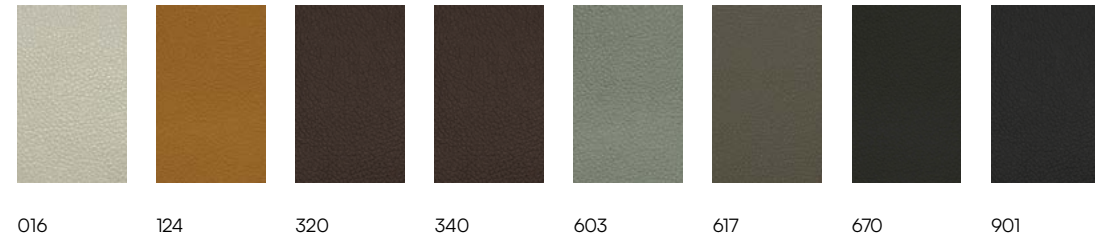

Material	100% Polyurethane	Fastness to rubbing	Grade 5 wet or dry
Width	Approximately 55 inches (140 cm ±3 )	Water	Water Repellent
Weight	Approximately 550 g/lin.m ±10%	Resistance	
Thickness	1,3 ± 0,15	Flammability	BS 5852 Part 1 Cigarette & Match Test
Tensile Strength	WARP >568N WEFT >620N		EN 1021-1 / 2 Cigarette & Match Test
Tear Strength	WARP >63N WEFT >61N		CA Tecxh Bull 117 NFPA 260 Cigarette Test
Durability	>500.000 rubs ISO 5470-2	Sustainability	Certified to OEKO-TEX®
Light fastness	7 (ISO 105 - B02)		

Category C  
Vita



Material	Surface: 98% PVC, 2%. PU Substrate: 100% Cotton	Flexes	Hydrostatic head BS 3424 Part 26 > 1 mt
Width	Approximately 55 inches (140 cm)	Waterproof	ISO 105 E03 colour change 4 for 10% chlorine solution
Weight	Approximately 1190 g/lin.m ±10%	Urea resistance	BS 3424 Part 19 no significant deterioration after 24 hrs
Durability	ISO 5470-2 100,000 rubs (Grade 2 min.)	Anti-microbial / Anti-AATCC 147 fungal	
Light fastness	6 (ISO 105 - B02)	Phthalate free	EN 15777
Fastness to rubbing	Wet: 4, Dry: 4 (ISO 105 - X12)	Residual extension	ISO 14704-1 Method A < 3% After 30 minutes
Flammability	EN 1021-1 (cigarette), EN 1021-2 (match) BS 7176 low hazard BS 5852 ignition source 5 (CRIB 5) BS 7176 medium hazard BS 5852 ignition source 7 (with interliner) UNI 9175 Classe 1 IM ISO 7854 Method B 400,000 Flexing cycles		

# Upholstery / Genuine Leather

## Category L1 Antik

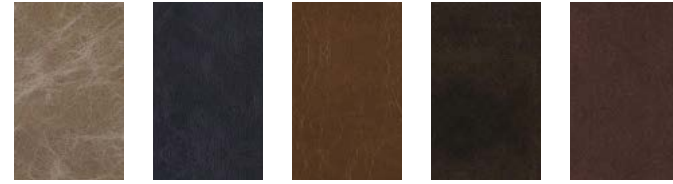

IWC Taş IWC Siyah IWC Electra Kızıl Rondo Yosun Rondo Kahve



\*\* Price will change according to the CRIB 5 application. Production time will be extended.



Material	European Cowhide	Light resistance	ISO 105 B02 ≥ 4
Finish	Full Aniline	Flammability	BS 5852: PART 1: 1979, CRIB 5**
Thickness	1.1 - 1.3mm		CAL 117
Weight	0.85- 0.95kg/sqm	Adhesion	UNI EN ISO 11664 ≥ 3 N / cm
Average size	4.3sqm	Flexes	TS EN ISO 32100 ≥ 20.000
Colour fastness to rubbing	DRY UNI EN ISO 11640 DRY @200 CYCLE ≥ 4 GREY SCALA P WET UNI EN ISO 11640 WET @50CYCLE ≥ 4 GREY SCALA P	Tear Strength	BS EN ISO 3377-1 ≥ 25 N
		Tensile Strength	BS EN ISO 3376 ≥ 10 N / mm
		Wellness	Gold Rated by LWG
		Application	Hospitality, Residential, Contract

## Category L1 Relax



380 Kırmızı 625 Camel 626 Açık Kahve 953 Siyah



\*Hide size may vary according to selected colour.



Material	European Cowhide	Light resistance	ECR 118.03, ANEX 6 7 8
Finish	Full Pigmented	Flammability	CRIB 5
Thickness	1.1 - 1.3mm		UNI EN ISO 11664 ≥ 5 N / cm
Weight	0.85- 0.95kg/sqm	Adhesion	TS EN ISO 32100 ≥ 100.000
Average size	4.2 sqm*	Flexes	BS EN ISO 3377-1 ≥ 25 N
Colour fastness to rubbing	UNI EN ISO 11640 DRY @1500 CYCLE ≥ 4 GREY SCALA UNI EN ISO 11640 WET @500 CYCLE ≥ 4 GREY SCALA	Tear Strength	BS EN ISO 3376 ≥ 12 N / mm
		Tensile Strength	Gold Rated by LWG
		Wellness	Hospitality, Automotive, Aircraft, Yacht, Railway
Light resistance	ISO 105 B02 ≥ 5		

## Category L2 Etna



16142 16196 16116 16140



\*Hide size may vary according to selected colour.

\* The price will change in accordance with FR, CRIB 5 and CAL 117 application, and the production time will be extended.

Care / Cleaning



Material	Bovine leather	Flammability	CRIB 5 **
Thickness	Approximately 0.9 mm		UNI EN ISO 1021-1/2**
Average size	4,50 m2*		BS 5852 1990 Sec. 4 NI/0-1**
Colour fastness to rubbing	IUF 450 / UNI EN ISO 11640-500 dry rubs (Grade 4 min.) IUF 450 / UNI EN ISO 11640-100 wet rubs (Grade 4 min.) IUF 450 / UNI EN ISO 11640-50 alkaline pH8 (Grade 4 min.)	Flexes	California T.B. 117** IUP 20 / UNI EN ISO 5402 (Grade 30.000 min.)
Light resistance	5 blue scale - IUF 402 UNI EN ISO 105-B02	Adhesion	IUF 470 / UNI EN ISO 11644 (Grade 3,50 N/cm min.)
		Tear Strength	IUF 40 / UNI EN ISO 3377-1 (Grade 20 N min.)

## Category L2 Lena

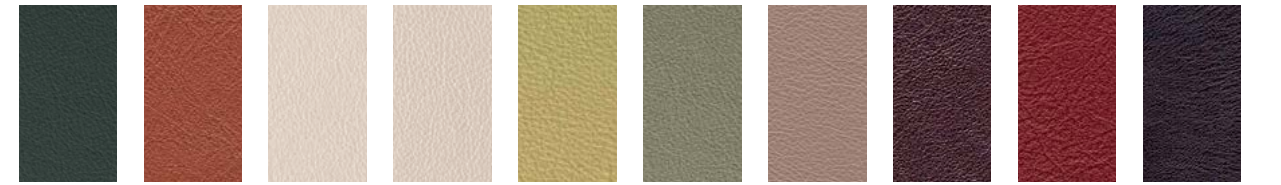

443 665 2266 2270 2535 3360 3396 5458 5484 Black



\*Hide size may vary according to selected colour.

\* The price will change in accordance with FR, CRIB 5 and CAL 117 application, and the production time will be extended.

Care / Cleaning



Material	Bovine leather	Flammability	CRIB 5 **
Thickness	Approximately 0.9 mm		UNI EN ISO 1021-1/2**
Average size	4,20 m2*		BS 5852 1990 Sec. 4 NI/0-1**
Colour fastness to rubbing	IUF450/UNI EN ISO 11640-500 dry rubs (Grade 4 min.) IUF 450/UNI EN ISO 11640-150 wet rubs (Grade 4 min.) IUF450/UNI EN ISO 11640-80 alkaline pH8 (Grade 4 min.)	Flexes	California T.B. 117** IUP 20 / UNI EN ISO 5402 (Grade 30.000 minimum)
Light resistance	5 blue scale - IUF 402 UNI EN ISO 105-B02	Adhesion	IUF 470 / UNI EN ISO 11644 (Grade 3,50 N/cm min.)
		Tear Strength	IUF 40 / UNI EN ISO 3377-1 (Grade 20 N min.)

Category L2  
Fantasy



613 Carpet Tobacco  
IWC Chain Black  
IWC Stone Lil Lizard  
IWC Rug Chestnut

\*Hide size may vary according to selected colour.



Material	Bovine leather
Thickness	Approximately 0,9 mm
Average size	4,50 m2*
Colour fastness to rubbing	IUF450/UNI EN ISO 11640-500 dry rubs (Grade 4 min.) IUF450/UNI EN ISO 11640-100 wet rubs (Grade 4 min.) IUF450/UNI EN ISO 11640-50 alkalineph8 (Grade4min.)
Light resistance	5 blue scale - IUF 402 UNI EN ISO 105-B02

Flammability	CRIB 5 ** UNI EN ISO 1021-1/2 BS 5852 1990 Sec. 4 NI/0-1 California T.B. 117
Flexes	IUP 20 / UNI EN ISO 5402 (Grade 30.000 minimum)
Adhesion	IUF 470 / UNI EN ISO 11644 (Grade 3,50 N/cm min.)
Tear Strength	IUF 40 / UNI EN ISO 3377-1 (Grade 20 N min.)

# Upholstery / Outdoor

Category A  
Malta 02

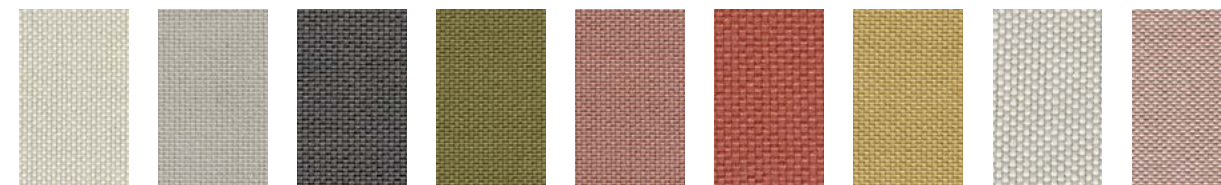

7410 1010 G1G1 5858 Z7Z7 1818 R8R8 74A2 Z774

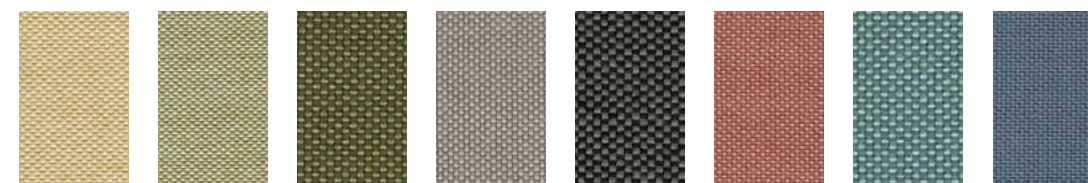

R874 5874 58CY 10CE G1X1 Z718 H244 4468



Material	%100 ROLEFIN
Width	Approximately 55 inches (140 cm)
Weight	Approximately 284 g/in.m
Durability	≥50,000 Martindale cycles (EN ISO 12947)
Wyzenbeek	70000
Pilling	5 (EN ISO 12945)
Light fastness	7 (ISO 105 - B04)
Tensile Strenght	WARP 1420WEFT 942 EN ISO
Tear Strenght	13934-1
Fastn. to rubbing	WARP 180 WEFT 111 EN ISO 13937-3 Wet: 4 Dry: 5 (ISO 105-X12)

Repellence	AATCC 193 - 8 ... to liquids AATCC 118 - 4 ... to oil EN ISO 105 - X18 4/5 ... to phenolic yellowing BS 5852 PART 1 SOURCE 0
Flammability	EN 1021-1, CALL 117 NFPA 260 EN ISO 4920 - 80
Spray test	GRS (Version 4) ,100% Recycled, ISO 14001
Sustainability	OEKO_TEX, MED Module D, Registered AS 91000

## Category C

P Heritage



Classe Natural, Classe Rock, Classe Yellow Stone, Maida Summer, Manso Anthracite, Manso Aurora, Manso Cyrilla, Manso Gold Finch, Manso Olive

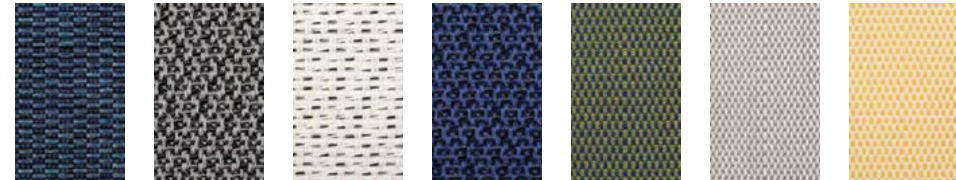

Omegna Anthracite, Omegna Anthracite, Omegna Natural, Omegna Royal, Rhemes Aurora, Rhemes Rock, Rhemes Summer

Care / Cleaning

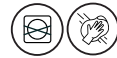

Material	%100 Solution Dyed Outdoor PES	Colour Fastness	4-5 (ISO 105-E02)
Width	165 cm (+/-3%)	... to sea water	4-5 (ISO 105-E02)
Weight	Classe: 264 gr/m2, Maida: 264 gr/m2, Manso: 327 gr/m2, Omegna: 361 gr/m2, Rhemes: 264 gr/m2	... to chlorine water	Classe, Maida, Rhemes, Omegna: 5 (Scale 1-5 ISO 4892-3)
Repeat	Plain	UV Test	Manso: 4 (Scale 1-5 ISO 4892-3) BS 5852 Source 0
Durability	Classe, Maida, Rhemes: Martindale 40000 rubs Manso, Omegna: Martindale 30000 rubs	Flammability	NFPA701 Class 1 Water and Stain Repellant: Mildew Resistant
Light fastness	7+ (ISO 105 B04)	Sustainability	Certified to OEKO-TEX®

## Category D

Patio

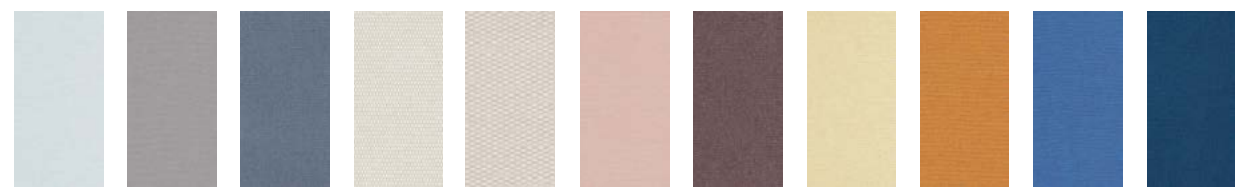

110, 150, 170, 210, 200, 340, 370, 410, 450, 750, 780

Care / Cleaning



Material	100% Trevira CS	... to sea water	4-5 (ISO 105-E02)
Width	Approximately 55 inches (140 cm)	Flammability	BS 5852 ignition source 5 (CRIB 5), BS 5852 part 1 ignition source 0, DIN 4102
Weight	Approximately 560 g/lin.m		B1, EN 1021-1/2, IMO FTP Code 2010 Part 8, NF D 60 013 / NF P 92 507 M1, UNI 9175 1IM, US Cal. Bull. 117-2013, ÖNORM B1/Q1, CRIB 5
Durability	≥50,000 Martindale cycles (EN ISO 12947)		
Pilling	4-5 (EN ISO 12945)		
Light fastness	5 (ISO 105 - B02)		
Fastness to rubbing	Wet: 4-5, Dry: 4-5 (ISO 105-X12)		
Colour fastness		Sustainability	Greeguard Gold, EN 15804, ISO
... to light	7 (ISO 105-B02)	Spray test	14040, HPD
... to weathering	6-7 (ISO 105-B04)	Soil repellent	Fluorocarbon-free water repellent finish, Note 3 (EN 4920)
... to chlorine water	4-5 (ISO 105-E03)		Note min. 4, depending on colour

## Category D

S Heritage



Alpine, Ash, Char, Dijon, Indigo, Leaf, Moss, Papyrus, Rust, Sky

Care / Cleaning



Material	50% recycled 47% Sunbrella® Acrylic 3% Polyester	Fastness to rubbing	Wet: 4 Dry: 5 (ISO 105-X12)
Finish	Water-Repellent & Stain-Proof, Déperlant & Anti-Taches	Wash Colour Fastness	
Width	EN 1773 Min. Useful width 137 cm	Colour fastness	ISO 105C06 Class / 5 - 5
Weight	ISO 3801 g/m² 335	... to weathering	
Durability	≥50,000 Martindale cycles (EN ISO 12947)	... to friction	
Wyzenbeek	70000	Spray test	ISO 105B04 - 1000 H Class / 5 - 4-5
Pilling	5 (EN ISO 12945)		OUTDOOR
Light fastness	ISO 105B02 Class / 8 - 8 UV INDOOR		Wet: ISO 105X12 Class / 5 - 5, Dry: ISO 105X12 Class / 5 - 5
Tensile Strength	WARP 1420WEFT 942 EN ISO 13934-1	Sustainability	ISO 4920, Class / 5, 5
Tear Strength	WARP 180 WEFT 111 EN ISO 13937-3		Greeguard, 50% Recycled, Reach Regulation, QSEE Certification, OEKO-TEX Label, Zero Landfill

## Category F

Amaral

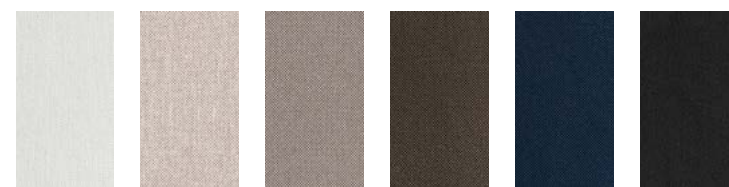

















08 Perla, 03 Lino, 02 Taupe, 01 Ebano, 10 Encre de Chine, 09 Nero

Care / Cleaning



Material	78% Polyvinyl Chloride, 20 Polyester, 2% Vinyl Acrylic Laquer	Durability	>100.000 rubs DIN 53863
Width	Approximately 55 inches (140 cm ±1 )	Adhesion	40N
Weight	Approximately 650 g/lin.m ±5%	Light fastness	5/5 (ISO 105 - B02)
Thickness	1,15 ± %5	Fastness to rubbing	Grade 6 wet or dry
Tensile Strength	WARP >245N WEFT >400N	Water Resistance	Water Repellent
Tear Strength	WARP >30N WEFT >25N	Sustainability	Certified to OEKO-TEX®

# Legend

-  Available for outdoor usage
-  Genuine leather
-  Waterproof
-  Sustainable Fabric
-  Wash at water temperature 30°C (80°F) or below
-  Water temperature 60°C (140°F) or below
-  Do not wash
-  Do not tumble dry
-  Tumble dry
-  Dry clean
-  Do not dry clean
-  Iron at low heat
-  Iron at medium heat
-  Wipe clean
-  Do not bleach
-  Bleach
-  Available for FSC certified material

\*Due to technical reasons and differences in monitors, it is not possible to guarantee the same tone between deliveries, colours of materials may also appear different to those shown on the catalogue.

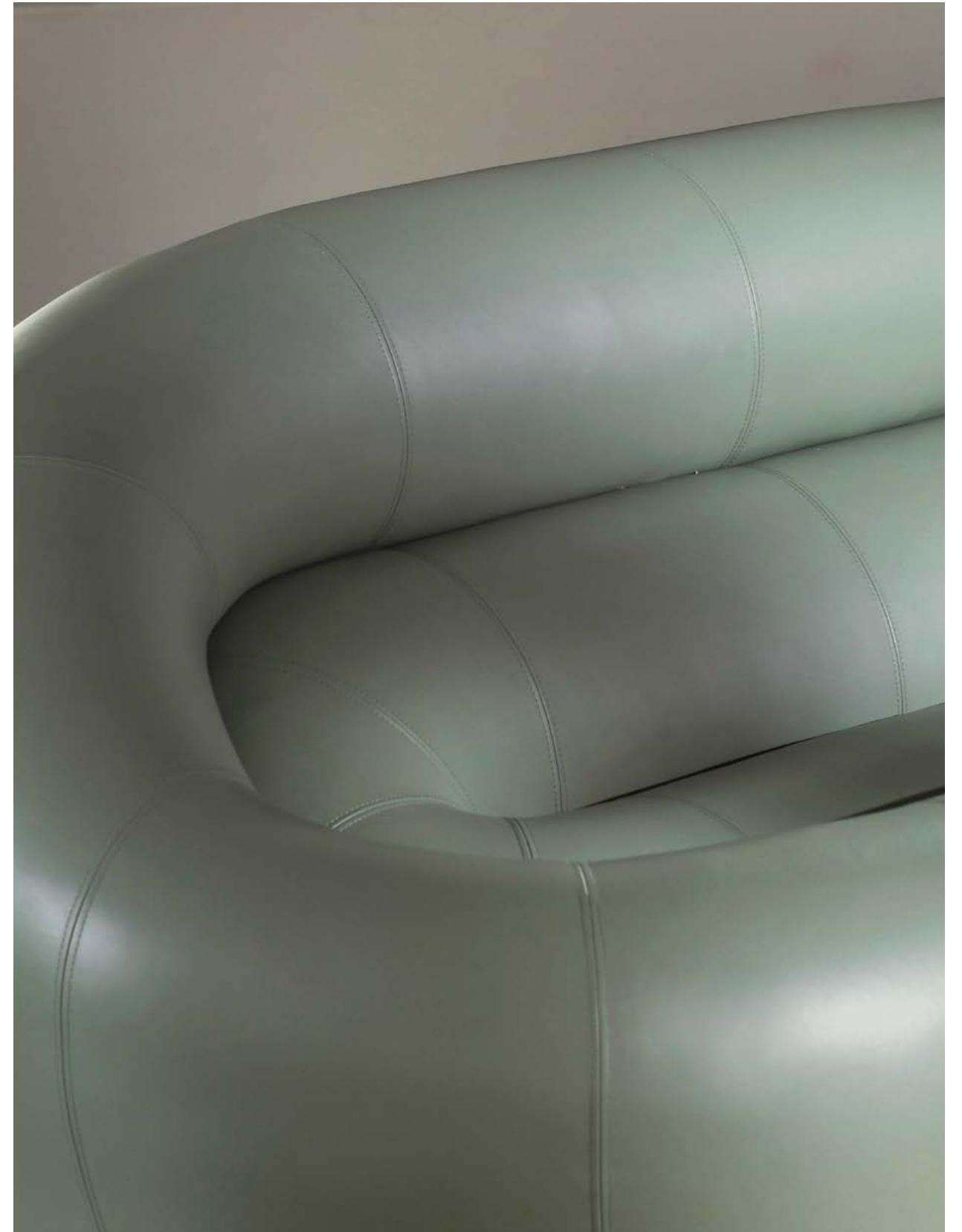

# Guide for Care & Maintenance



Thank you for choosing Parla.

Our mission is to manufacture products that meet the highest standards in design, quality and functionality.

Regular professional care extends the life time of each product and thus also your satisfaction with its use. You can find some useful information on how to use and carefully maintain our products below.

## SOLID WOOD INDOOR USE

The Solid wood we use is an actual living part of the tree it comes from, and is composed of wood fibers that are held together with adhesives.

At Parla, our most popular choice of solid wood is Beech, and what we do is create pieces of lumber that have their own characteristics; unique in grain pattern, colour, and texture. As a result each piece of solid wood displays different behaviour and form when different carving techniques are used. Unlike wood veneer, solid wood pieces are frequently used for curved and multi-dimensional pieces.

### ASH

With a neutral colour base, ash trees are very durable and robust. Ash also has better resistance to sunlight and its possible corruptive effects.

### BEECH

Having a light-pink undertone, beech wood is very easy to form, therefore easy to use for curved shapes and round corners requiring further surface processing. Parla Collection products are generally produced using Beech wood.

### RECOMMENDATIONS

We recommend cleaning the surface regularly with a slightly damp soft cloth. Do not use heavy chemicals for cleaning purposes and protect the surface from sharp objects to avoid scratching.

\*As wood is a living material, variations in colour, pattern, and pigmentation will occur on each piece.

\*Wooden furniture will also change appearance over time as it is affected by the environment (daylight, humidity, etc.) in which it is placed.

\*Solid wood furniture should not be placed too close to heat sources nor should it be in frequent contact with liquids.

\*Do not use abrasive materials.

## WOOD VENEER INDOOR USE

A veneer refers to a thin layer of wood peeled or cut from a section of a tree. It is then bonded onto a thick piece of wood, typically MDF, chipboard, or plywood. These layers are classified later according to their cutting technique and final patterns. At Parla, we use quarter cut veneer sheets with slip matching on plywood as standard. Each veneer table layer is unique. No matter how expertly cut or treated, none of its layers are identical to another, which is the charm of using natural materials. Veneer provides high-quality looks without the need for large amounts of wood consumption.

### OAK

A somewhat brittle material when processed, oak is very resistant to heavy weather conditions and harsh climates as a tree. Being a durable and robust form, oak pieces require expertise and unique production techniques.

### WALNUT

A tree familiar with mild climates, the walnut tree has high fibers resulting in splendid and rich patterns on its layers. Easy to process, walnut has high aesthetic qualities however it requires suitable methods to bring out its beauty and strength.

### RECOMMENDATIONS

We recommend cleaning the surface regularly with a slightly damp soft cloth. Please wipe the veneer following the direction of the wood grain. Compared to solid wood, wood veneer is less resistant to heat and moisture, especially around the edges where layers of wood are visibly pressed. Extreme heat and any contact to water must be avoided, especially around the edges.

\*Veneers generally have color differences compared to their matching solid wood stain options. Which are usually used for chair legs or supportive elements. We, therefore, especially recommend using wood veneer material for stained table tops and legs.

\*Do not use oil or ammonia-based products to clean wood veneer.

\*Do not use abrasive materials.

## METAL INDOOR USE

Metal, brass, aluminium, and stainless steel are the most preferred materials at Parla for the metal components of furniture we produce. Depending on the product type and place of use, metal surfaces are available in Powder Coated Textured (outdoor) or Matt (indoor) or PVD Coated; Polished or Brushed (indoor) finishes.

### STAINLESS STEEL

Durable and more accessible, stainless steel is perfect for structural elements and metallic finishes. PVD coating can be used with different finishes, as shown in our coloured steel options.

## METAL & ALUMINIUM

Parla recommends Powder Coated metal in matt finish for indoor use and aluminium or treated metal in textured finish for outdoor use. Aluminium is a rust-resistant and light material that can be used directly with powder coating without further treatments. However, we recommend using powder coated aluminium with a textured finish to increase the hold of coatings that protect the metal from heavy conditions of outdoor use.

Metal materials on the other hand need to be pre-coated with cathoporesis treatment before coating for protection over rust and corrosion.

## RECOMMENDATIONS

We recommend cleaning the surface with a damp cloth and wiping the surface immediately after.

\*Do not use alcohol.

\*Avoid using abrasive materials that can alter or scratch the surface.

\*For PVD coatings, Parla uses an environmentally friendly Anti Fingerprint solution. Creating a protective layer over stainless steel, this solution creates an easy-to-clean surface, reducing fingerprints.

\*It is not recommended to use PVD Coated steel under direct sunlight for extended periods since it can affect the coating colour over time.

## GLASS & STONE

### GLASS

Characteristic results of glass manufacturing such as tiny air bubbles, thickness variations and light pitting, should always be expected with glass. All glass used in our furniture is tempered to ensure excellent durability. For painted glass, all RAL colour options are available and the final finish is tempered extra clear glass with colour.

### MARBLE & STONE

Travertine Stone and marble are natura and porous materials of sedimentary origin. They are usually collected as stone blocks which are later cut into layers of stone using a delicate process. The texture of these stones depends on grains. The formed and pressured element groups to create mesmerising grains and layers makes each piece unique. The density of these element groups determines the colour and patterns of the stone.

Before using them as furniture parts stones are treated with an invisible solvent-based chemical to

sustain their surface integrity. It penetrates stone pores and protects their surface against dirt, dust, water or stains, generating an easy clean effect. Due to its porous nature this treatment must be applied every few months to help the surface reach its entire service life.

## RECOMMENDATIONS

We recommend carefully cleaning the surface with a barely damp soft cloth to avoid scratching the surface.

Marble is porous and has a poor resistance to acidic substances (vinegar, lemon juice, wine, tea, coffee, etc.) that even in small quantities can corrode the surface and penetrate into the pores forming mat spots.

\*Do not use any products containing acetone ammonia, chlorine, solvents, abrasive products and furniture polish, since these might permanently damage the surface of the product making it look opaque with marks.

Glass is not scratch-resistant so avoid dragging objects across the surface. Glass is very resistant to heat sources. Still we recommend never placing hot objects directly on the surface since high temperature differences creates fragile spots on the surface which, could result in cracks.

\*Glass surfaces should be wiped with a clean dry cloth. Cleaning can be done with household ammonia or unique glass cleaning products if the occasion requires it.

\*Never use abrasives or sharp -edged tools to prevent scratching.

## OUTDOOR

In the Parla collection, outdoor furniture is categorized into two types: All-Weather and Weather-Resistant, each designed for different environmental conditions and maintenance needs.

All-Weather furniture is built to endure harsh conditions like rain, snow, intense sun, and humidity. Crafted from durable materials such as Iroko wood, aluminum, stainless steel, rope, and quick-dry foam cushions, it requires minimal upkeep—occasional cleaning is sufficient. Ideal for open spaces, it doesn't require covers, but using them can extend its lifespan.

Weather-Resistant furniture offers moderate protection against mild rain, UV exposure, and limited moisture. Made from powder-coated metal and standard outdoor cushions, it needs periodic maintenance, such as re-coating and refinishing. Best suited for partially sheltered areas, it requires covers during harsh weather, and cushions should be stored indoors when not in use.

## SOLID WOOD

### OUTDOOR USE - IROKO

Iroko is a particular type of timber that grows in rainforest weather conditions, making it highly durable for outdoor use. With its high density of fibers, Iroko can extract minerals and particles from the soil. Because of these features, Iroko grows much faster than traditional timber types and can be produced in a fast-paced sustainable cycle.

Iroko also showcases its stain colors distinctively due to its unique, light yellow based color.

## METAL & ALUMINIUM

### OUTDOOR USE

Since it is rust-proof, we use powder coated aluminium or pre-treated and powder coated metal structures for outdoor furniture.

For outdoor use, we recommend powder coated metals with a textured finish, pre-coated with cathoporesis treatment to increase the paint's grip and protect the metal from heavy conditions of outdoor use.

For aluminium, powder coating can be applied directly.

## ROPES

The weaving technique and rope options create a vast playground for furniture designers. With round and flat options, hand woven ropes are carefully placed according to templates by professionals constructed by very skilled craftsmen. Woven from pre-UV treated strands, outdoor ropes also have a multi-layered internal structure, making them highly resistant to tension, colour fade and heavy weather conditions.

## RECOMMENDATIONS

We recommend cleaning the Iroko surface regularly with a slightly damp soft cloth.

\*Do not use heavy chemicals for cleaning purposes and protect the surface from sharp objects to avoid scratching.

\*Although they can be in touch with it, outdoor furniture mustn't be in direct contact with salt water for long periods of time since it can cause corrosion. Also, direct exposure to sunlight for extended periods will eventually affect Iroko's colour.

\*Do not use any chemicals for cleaning powder coated metal, clean with damp cloths or water.

\*For extreme weather conditions, UV treatment types for outdoor ropes may vary. Please specify area of use to select the suitable treatment type.

## UPHOLSTERY

### GENUINE LEATHER

Natural leather has a pleasant characteristic smell and is wear resistant. Its quality depends on the animal's lifestyle as well as on the method of leather processing. Minor defects originating during the animal's life, such as wrinkles, blood veins, scars, scratches, etc. are regarded as permissible and are even required as evidence of the 'genuine and unique' quality of the leather.

## RECOMMENDATIONS

The best maintenance for leather is regular vacuuming with a soft brush. Avoid using cleaning products and sharp objects. If cleaning is necessary use boiled water with natural soap shavings of good quality. Whip 2-3 tablespoons of soap flakes in 1-liter water and only use the foam. Apply the foam with a soft cloth, let the furniture dry and dry afterward the leather off thoroughly with a soft cotton cloth.

### ARTIFICIAL LEATHER

Artificial leather is usually undemanding in maintenance.

## RECOMMENDATIONS

Remove dust regularly with a fine suction force of your vacuum cleaner or with a wet cotton cloth.

\*Dry spilled liquids immediately by a dry cotton or paper towel.

\*Do not let other stains dry on the surface but remove them immediately with lukewarm water.

\*Wipe the surface carefully with a moistened cotton cloth and dry with a dry towel.

## FABRIC

Cleaning and maintaining upholstered furniture regularly is important to retain the appearance of the fabric and to prolong its lifespan. Over time, dust and dirt can cause furnishing fabrics to change color and exacerbate wear.

## RECOMMENDATIONS

Vacuum the furniture regularly using the upholstery nozzle to remove dust and avoid fluff and pilling. Straighten the fabric with your hands from time to time. Wrinkles in the fabric can be straightened using a steamer. Soak up spilled liquids immediately with an absorbent napkin or cloth by dabbing gently towards the centre of the stain.

\*Never use concentrated detergents or bleach, ammonia, optical brighteners or soap intended for hard surfaces.

\*We do not recommend spot cleaning of individual marks and stains as this damages the fabric and causes colour loss.

\*Avoid rubbing the material hard as this could result in loss of colour and damage the fabric.

## We kindly ask you to follow

**instructions and recommendations contained in this manual.**

Regular professional care extends the life of your product and besides can be also a condition for warranty compensations. The manufacturer does not take any responsibility for potential damage to the product resulting from unauthorised use and unprofessional handling of the furniture.

Parla is constantly working on further development of all products, which may cause some changes in used materials, constructions and finishing.

As a result of this the recommendations and guidelines for the proper use of products may be also changed. Thank you for your understanding and we wish you pleasant moments spent while using our products.

\*The products displayed in this catalogue are to be considered as sample configurations. The textures, colors of materials, and finishes are indicative due to variations that may result from the printing process.

For any technical specifications and/or dimensions, please get in contact with our sales team. Parla Design reserves the right to change, without prior notice, materials, covers, finishes, and drawings presented in this catalogue.



parladesign.com

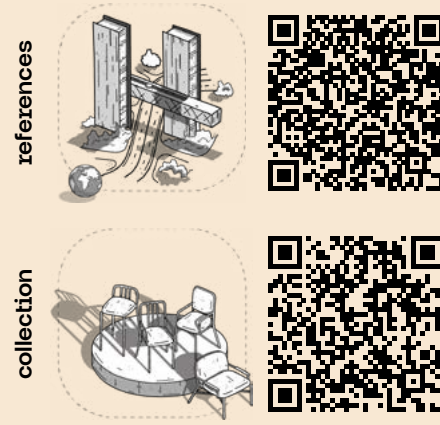

#### Parla Showroom

Bareli İş Merkezi, Ayazmadere Cad.  
Pazar Sok. No: 2-4  
Beşiktaş 34349 - İstanbul, TURKIYE  
+90 (212) 216 61 63 / 64  
[info@parladesign.com](mailto:info@parladesign.com)

#### Parla Factory

Boğazköy Atatürk Mah.  
Yıldırım Beyazıt Cad. No: 194  
Arnavutköy 34285 - İstanbul, TURKIYE  
+90 (212) 685 01 42

#### Parla UK

+44 (0) 20 3865 7703  
[london@parladesign.com](mailto:london@parladesign.com)

#### Parla UAE

+971 4 553 07 28  
[dubai@parladesign.com](mailto:dubai@parladesign.com)

#### Parla USA

Parla Design INC.  
[usa@parladesign.com](mailto:usa@parladesign.com)

parladesign.com

#### THE IMPRINT

©2025 Parla

*All rights reserved. No part of this publication may be reproduced, stored in a retrieval system or transmitted in any form or by any means, electronic, mechanical, photocopying, recording or otherwise; without the prior permission of the copyright owner.*

Ask for our FSC®-certified products

